

MITCHELL & O'SHEA DRAIN 2026

Township of Lucan Biddulph



SPRIET
ASSOCIATES
ENGINEERS & ARCHITECTS
155 York Street
London, Ontario N6A 1A8
Tel. (519) 672-4100
Fax (519) 433-9351
Email: mail@spriet.on.ca
www.spriet.on.ca

London, Ontario
February 12, 2026

MITCHELL & O'SHEA DRAIN 2026

Township of Lucan Biddulph

To the Mayor and Council of
The Township of Lucan Biddulph

Mayor and Council:

We are pleased to present our report on the reconstruction of parts of the upper closed portion of the Mitchell Municipal Drain and the lower portion of the O'Shea Municipal Drain serving parts of Lots 11 to 16, Concessions 6 to 9 and Lots 13 to 16, North Boundary Concession in the Township of Lucan Biddulph. The total watershed area contains approximately 377 hectares.

AUTHORIZATION

This report was prepared pursuant to Section 78 of the Drainage Act. Instructions were received from your Municipality with respect to a motion of Council. The work was initiated by requests from affected landowners.

HISTORY

A major reconstruction of the Mitchell Drain was completed pursuant to a report by C.P. Corbett, P. Eng., dated December 15, 1969. This report covered the reconstruction of the open ditch from its outlet in the Ausable River at Lot 17, Concession 4, upstream to its head at the line between Lots 13 and 14, Concession 7. The report also provided for the replacement of the open ditch across Lots 12 and 13, Concession 7 with a dual tile system and surface waterway (Drains A and B) and the construction of nine additional tile branch drains. The design coefficient for the capacity of the tiles was 13mm per 24 hours.

The O'Shea Drain was originally constructed as an open drain pursuant to a report by C.P. Corbett, P. Eng., dated July 13, 1960.

The O'Shea Drain open portion across Lots 14 to 16, Concessions 8 and 9 was replaced with a 450mm to 200mm tile drain and shallow surface waterway pursuant to a report by A.J. DeVos, P. Eng., dated February 14, 1977. The report also provided for the deepening and improvement of the remaining ditch on Lot 14, Concession 7. The design coefficient for the capacity of this tile was between 13mm and 19mm per 24 hours.

The open portion of the Mitchell Drain across Lot 14, Concession 7 was replaced with twin 750mm tiles to the O'Shea Drain junction, a single 750mm to 525mm tile from there to the existing tile outlet, and an overflow swale pursuant to a report by M.P. DeVos, P. Eng., dated June 30, 2003. The construction included a gabion gasket drop headwall outlet structure, cleanout of the ditch to Roman Line, a fish pool, and sediment basin.



HISTORY (cont'd)

This 2003 report also provided for the remaining O'Shea Drain open ditch to be replaced with 675mm to 600mm tile and overflow swale. The design coefficient for capacity of the 2003 portion of the Mitchell Drain is 25mm per 24 hours and 37mm per 24 hours for the O'Shea Drain.

The existing Drain 9 was extended upstream south-easterly through the bush in Lot 13, Concession 8 pursuant to a report by J. Brown, P. Eng. The work consisted of 287 meters of open ditch to provide outlet for the private tiling at the edge of the bush.

EXISTING DRAINAGE CONDITIONS

A site meeting was held with respect to the project and through later discussions the owners reported the following:

- that the existing tile portions (Main Drain and Branches, Branch Drains 5, 8, and 9) are too small and are not working satisfactorily
- that the O'Shea Drain is also not providing satisfactory drainage from the Mitchell Drain junction to the east side of the Mitchell Line and that a portion is in poor condition
- that the owners requested the following:
 - that the O'Shea Drain be replaced with a new tile designed to a 51mm per 24 hours capacity from Mitchell Line downstream
 - that we investigate replacing and relocating the O'Shea Drain from the line between Concessions 7 and 8, to a direct outlet into the Damen Drain open ditch where it meets the line between Lots 15 and 16, Concession 7, instead of adding additional tiles adjacent to the Mitchell Drain 2003 tiles
 - that the 1969 Main Drain tiles be upgraded with an additional tile and that Drain 5 and 9 tiles be replaced to improve the capacity to today's 38mm per 24 hours design standard
 - that the tile portion of Drain 9 be replaced with a new larger tile and that the ditch be cleaned out
 - that a lead be constructed from Drain 8 east to the line with property 30-097 to provide a drainage outlet and that the portion of Drain 8 from the lead downstream to the main drain be replaced with a new larger tile

A field investigation and survey were completed. Upon reviewing our findings, we note the following:

- that the Drain 9 open portion has silted in and does not provide a proper outlet for tributary sub-surface drainage tiles
- that the existing tile portions of the Mitchell Drain, Branches, and O'Shea Drain are considerably undersized by today's standards and are in poor working condition



EXISTING DRAINAGE CONDITIONS (cont'd)

- that there is erosion through the surface runs in the affected watershed area and flooding of the low-lying areas
- that some of the Mitchell Drain branches are in good working condition and have not been requested to be replaced. These tiles were not investigated
- that it is feasible and economical to relocate the lower portion of the O'Shea Drain in Concession 7 from its present outlet into the Mitchell Drain tile to the Damen Drain open ditch. This means that the 2003 portion of the Mitchell Drain would not require additional twin 750mm tiles adjacent to the existing twin 750mm tiles to accommodate the improved O'Shea Drain

We investigated the previous requests, including requests for designs and costs for both 38mm and 51mm per 24 hours capacities. Preliminary design, cost estimates, and assessments of these alternatives were prepared, and informal public meetings were held to review the findings and preliminary proposals. The following further input and requests were provided by the affected owners at that time and at later dates:

- that 63mm and 51mm design be used for the O'Shea Drain and 51mm design for Drain 5
- that the outlet of the O'Shea Drain from the line between Concessions 7 and 8 be relocated into the Damen Drain open ditch
- that the existing tile portion of the O'Shea Drain upstream of Mitchell Line shall not be replaced or improved at this time
- that the 38mm capacity be used for the improved and replaced portions of the Mitchell Drain

DESIGN CRITERIA AND CONSIDERATIONS

The Drainage Coefficient method contained in "DRAINAGE GUIDE FOR ONTARIO", Publication 29 by the Ontario Ministry of Agriculture, Food, and Agribusiness (OMAFRA) is typically used to design municipal drains. The Drainage Coefficient defines a depth of water that can be removed in a 24 hour period and is expressed in millimetres per 24 hours. The coefficients used to design the Mitchell Main Drain and Drains 8 & 9 with respect to capacity was 38mm per 24 hours and 51mm per 24 hours for Drain 5.

The coefficients used to design the O'Shea Drain was 51mm per 24 hours in Concession 8 and 63.5mm per 24 hours in Concession 7 (relocated portion).

We would like to point out that there have been no indications of any adverse soil conditions, but this region is known to have stones present. It should be noted that no formal soil investigation has been made, with this information being provided by the owners and Middlesex County Soil Mapping.

The proposed design and report have been generally completed using the "GUIDE FOR ENGINEERS WORKING UNDER THE DRAINAGE ACT IN ONTARIO" OMAFA Publication 852.



RECOMMENDATIONS

We are therefore recommending the following:

OPEN PORTION:

- that the existing ditch bottom of Drain 9 be cleaned out to provide a proper sub-surface drainage outlet
- that, due to the depth and slope of the existing drain, little or no material will be excavated from the ditch bottom
- that excavated material be levelled adjacent to the drain
- that the ditch bottom and ditch slopes be cleared only (stumps are to be left) of trees, brush, and scrub
- that the working space and access route be cleared and grubbed of trees, brush, and scrub where required for machines to access and complete the work on the ditch and the areas where excavated material is to be levelled
- that the stumps, logs, and brush be piled beyond this width

CLOSED PORTION:

- that the existing tile portions of Drains 5, 8, and 9 be replaced with a new 200mm to 450mm concrete tile and sewer pipe, including related appurtenances, and that the existing tile be destroyed where possible
- that the existing tile portions of O'Shea Drain in Concession 7 be relocated from its outlet in the Mitchell Drain tile to an outlet in the Damen Drain open ditch with a new 750mm to 825mm concrete tile including related appurtenances
- that the remaining existing portions of the O'Shea Drain in Concession 7 be officially abandoned as municipal drain under Section 19 of the Drainage Act. The owners may maintain it as private header tiles if they so wish
- that the portion of the O'Shea Drain in Concession 8 and across Mitchell Line be replaced with 525mm to 675mm concrete tile, including related appurtenances, be constructed to provide a proper surface and sub-surface drainage outlet, and that the existing tile be destroyed where possible
- that a new 750mm concrete tile be constructed adjacent, and work in conjunction with, the existing 1969 Mitchell Main Drain tiles, including cross connections and related appurtenances
- that catchbasins be installed at various locations on the proposed drains to allow direct surface water entry into the tiles and thereby reduce surface flow and erosion
- that the existing portions of the Mitchell Drain and the portions of the O'Shea Drain east of Mitchell Line be included as part of this report for future maintenance purposes



RECOMMENDATIONS (cont'd)

Our design includes the wrapping of tile joints with geotextile to prevent the incursion of fine soil particles into the drain. If areas of poor soil are encountered at the time of construction, it may become necessary to install the tile on crushed stone bedding wrapped with geotextile or substitute plastic filter tile through such areas. The additional costs of such work would be an extra to the project. These areas are typically identified at the time of construction but may only become apparent after construction is completed. In this case, the extra costs for removal and reinstallation on stone bedding would be an extra to the project and if already billed become a supplementary billing.

In accordance with the principals of Section 14(2) of the Drainage Act, the existing surface waterway along the route of the tile drain(s) shall be part of the drainage works for future maintenance. The width available for the waterway shall be equal to the maintenance working width as noted on the Contract Drawings.

It is recommended that basement, cellar, or crawlspace drains be directed to a sump and then discharged onto the ground surface well away from foundations and septic systems or should owners desire to connect these drains to the new outlet drain, then it is suggested that they not be directly connected to the drains. Rather it is suggested that such a connection be made by an indirect method such as by sump pump with an open-air connection such as a mini-catchbasin, crushed stone filled excavation connected to a storm P.D.C. and should include a check valve and be piped above foundation level. It is noted that there is still a risk of flooding even with indirect methods of connection and any/all responsibility shall be borne by the owner. Downspouts from eavestroughs should be directed onto the ground surface well away from foundations and septic systems and are **not** permitted to be connected to the Municipal Drain.

ENVIRONMENTAL CONSIDERATIONS AND MITIGATION MEASURES

Based on the information available, there are no significant wetlands, sensitive areas, or endangered species along the route of the drains. The proposed construction of the Mitchell and O'Shea Drains 2026 includes quarry stone outlet protection and surface inlets which greatly help reduce the overland surface flows and any subsequent erosion. A temporary flow check of silt fencing is to be installed in the ditch downstream of the tile outlet for the duration of the construction.

We are also recommending that the following erosion and sediment control measures be included as part of our reconstruction proposal for the open portion of Drain 9 to help mitigate any potential adverse impacts of the proposed drainage works on water quality and fishery habitat:

- timing of construction is to be only at times of low or no flow
- a temporary flow check of silt fencing is to be installed for the duration of the construction at the bottom end of the ditch cleanout
- a cleanout of the ditch bottom only has been specified so that the existing bank vegetation is not disturbed. However, where the existing banks are unstable, or may become unstable, they are to be resloped and seeded as noted on the plans
- all work is to be completed from the east side of the ditch where possible. Any natural vegetation, brush, trees, etc. that exist on the unaffected sides of the ditch, especially the south side, should be retained to provide shade and cover



ENVIRONMENTAL CONSIDERATIONS AND MITIGATION MEASURES (cont'd)

- the existing tile outlets at the end of Drain 9 are to be protected with quarry stone rip-rap protection

SUMMARY OF PROPOSED WORK

The proposed work consists of approximately 281 lineal meters of open ditch cleanout including quarry stone rip-rap bank protection and approximately 4,241 lineal meters of 200mm to 825mm concrete field tile and HDPE sewer pipe, including related appurtenances.

SCHEDULES

Three schedules are attached hereto and form part of this report, being Schedule 'A' - Allowances, Schedule 'B' - Cost Estimate and Schedule 'C' - Assessment for Construction.

Schedule 'A' - Allowances. In accordance with Sections 29 and 30 of the Drainage Act, allowances are provided for right-of-way and damages to lands and crops along the route of the drain as defined below.

Schedule 'B' - Cost Estimate. This schedule provides for a detailed cost estimate of the proposed work which is in the amount of \$999,500.00. This estimate includes engineering and administrative costs associated with this project.

Schedule 'C' - Assessment for Construction. This schedule outlines the distribution of the total estimated cost of construction over the roads and lands which are involved.

Drawing No.'s 1 to 3, Job No. 224185, and specifications form part of this report. They show and describe in detail the location and extent of the work to be done and the lands which are affected.

ALLOWANCES

RIGHT-OF-WAY: Section 29 of the Drainage Act provides for an allowance to the owners whose land must be used for the construction, repair, or future maintenance of a drainage works.

For tile drains where the owners will be able to continue to use the land, the allowance provides for the right to enter upon such lands, and at various times for the purpose of inspecting such drain, removing obstructions, and making repairs. Also, the allowance provides for the restrictions imposed on those lands to protect the right-of-way from obstruction or derogation. The amounts granted for right-of-way on tile drains is based on a percentage of the value of the land designated for future maintenance. Therefore, the amounts granted are based on \$9,000.00/ha. through cropped lands and \$3,500.00/ha. through bush. These values are multiplied by the hectares derived from the width granted for future maintenance and the applicable lengths. No right-of-way was previously provided any of the existing Mitchell Drain and Branches being replaced or twinned. Right-of-way was previously provided for the O'Shea Drain.



ALLOWANCES (cont'd)

For existing open ditches, the right-of-way to provide for the right to enter and restrictions imposed on those lands is deemed to have already been granted.

Where the new tile drain is installed adjacent to the existing drain as a dual tile system, the allowance for right-of-way was granted in a previous report, and then right-of-way is granted only for the additional working width provided.

DAMAGES: Section 30 of the Drainage Act provides for the compensation to landowners along the drain for damages to lands and crops caused by the construction of the drain. The amounts granted are based on \$5,500.00/ha for closed drains installed with a wheel machine and \$4,000.00/ha. for open ditch work through bush with excavated material levelled adjacent to drain. These base rates are multiplied by the hectares derived from the working widths shown on the plans and the applicable lengths.

ASSESSMENT DEFINITIONS

In accordance with the Drainage Act, lands that make use of a drainage works are liable for assessment for part of the cost of constructing and maintaining the system. These assessments are known as benefit, outlet liability, and special benefit as set out under Sections 22, 23, and 24 of the Act.

BENEFIT

Benefit as defined in Section 22 of the Drainage Act means the advantages to any lands, roads, buildings or other structures from the construction, improvement, repair, or maintenance of a drainage works such as will result in a higher market value, increased crop production, improved appearance, better control of surface water, or any other advantages relating to the betterment of lands, roads, buildings, or other structures.

Special Benefit is assessed to lands for which some additional work or feature has been included in the construction repair or improvement of a drainage works. The costs of such work are separated and assessed independently from the regular work. These assessments can be made under Section 22 and/or 24 depending on the type of work.

Benefit By Cut-Off is assessed to lands or roads (under Section 23) which obtain relief from surface and/or sub-surface drainage onto or through their lands by the diversion of said surface and/or sub-surface drainage into another watershed.

OUTLET

Outlet liability is assessed under Section 23 to lands or roads that may make use of a drainage works as an outlet either directly or indirectly through the medium of any other drainage works or of a swale, ravine, creek, or watercourse.

In addition, a Public Utility or Road Authority shall be assessed for and pay all the increased cost to a drainage works due to the construction and operation of the Public Utility or Road Authority. This may be shown as either benefit or special assessment.



ASSESSMENT

A modified "Todgham Method" is typically used to calculate the assessments shown on Schedule 'C'- Assessment for Construction. This entails breaking down the costs of the drain into sections along its route where warranted and then extracting Special Assessments and Special Benefit Assessments from each section.

The remainder is then separated into Benefit and Outlet Assessments. The Benefit is distributed to those properties receiving benefit as defined under "Assessment Definitions", with such properties usually being located along or close to the route of the drain. The Outlet is distributed to all properties within the watershed area of that section on an adjusted basis. The areas are adjusted for location along that section and relative run-off rates. Due to their different relative run-off rates forested lands are assessed for outlet at lower rates than cleared lands. Also, roads and residential properties are assessed for outlet at higher rates than cleared farmlands.

The actual cost of the work involving this report, with the exception of Special Assessments, is to be assessed on a pro-rata basis against the lands and roads liable for assessment for special benefit, benefit, and outlet as shown in detail on Schedule 'C' - Assessment for Construction. The Special Assessments shall be levied as noted in the Section "Special Assessment".

The cost to restore water supply for any well determined to be impacted by any construction covered under this report shall become part of this report and be pro-rated with the costs provided for in this report.

SPECIAL ASSESSMENT

In accordance with Section 26 of the Drainage Act, a Special Assessment has been made against the Ministry of Transportation Ontario being the increased cost to the drainage work for boring a 610mm smooth wall steel pipe across their road allowance on the O'Shea Drain, due to the construction and operation of Mitchell Line (Highway 23). The Special Assessment shall be made up of the actual cost of this work and both the final and estimated values of the Special Assessment are to be calculated as follows:

Drain	Cost of Work	Less Equivalent Drain Cost (Fixed)	Plus Geotechnical Cost	Plus Administration Cost	Plus Interest, Contract Security, & Net H.S.T.	Special Assessment
O'Shea Drain	\$26,280.00	\$1,950.00	\$36,670.00	\$11,200.00	\$3,390.00	\$75,590.00

In accordance with Section 26 of the Drainage Act, a Special Assessment has been made against Quadro for the cost of locating and determining the elevation of their fibre optic cables on Mitchell Line, being the increased cost to the O'Shea Drain due to the construction and operation of their utilities. The Special Assessment shall be as shown on Schedule 'C'.

If any additional work is required to the drainage works due to the existence of buried utilities such as gas/water/oil pipelines, communications cables, etc. or if any of the utilities require relocation or repair then the extra costs incurred shall be borne by the utility involved in accordance with the provisions of Section 26 of the Drainage Act. This shall apply for work through this report and for future maintenance.

GRANTS

In accordance with the provisions of Section 85 of the Drainage Act, a grant **may** be available for assessments against privately owned parcels of land which are used for agricultural purposes and eligible for the Farm Property Class Tax rate. Section 88 of the Drainage Act directs the Municipality to make application for this grant upon certification of completion of this drain. The Municipality will then deduct the grant from the assessments prior to collecting the final assessments. It should be noted that all costs to increase the design standard on O'Shea Drain above the 38mm per 24 hours is assessed separately and shown not to receive the grant.

MAINTENANCE

Upon completion of construction all owners are hereby made aware of Sections 80 and 82 of the Drainage Act which forbid the obstruction of or damage or injury to a municipal drain. This includes tree roots penetrating tiles from trees planted by owners or naturally occurring. For tiles through bush areas, we recommend the owner maintain the cleared space by either mowing (hay) or growing a crop over it. If no maintenance is completed over several years, we recommend the Municipality complete the mowing/clearing as part of maintenance at the discretion of the Drainage Superintendent.

After completion, the entire Mitchell Main Drain from the former O'Shea Drain junction to its upstream end including the existing tiles shall be maintained by the Township of Lucan Biddulph at the expense of all upstream lands and roads assessed in Schedule 'C' - Assessment for Construction and in the same relative proportions until such time as the assessment is changed under the Drainage Act.

After completion, Branches 5, 8, and 9 of the Mitchell Drain and the portion of the O'Shea west of Mitchell Line, including the Highway, shall be maintained by the Township of Lucan Biddulph at the expense of all upstream lands and roads assessed in Schedule 'C' - Assessment for Construction and in the same relative proportions until such time as the assessment is changed under the Drainage Act.

After completion, the 2003 portion of the Mitchell Drain shall be maintained by the Township of Lucan Biddulph at the expense of the upstream lands and roads assessed in Schedule 'C' - Assessment for Construction in the June 30, 2003 report and in the same relative proportions until such time as the assessment is changed under the Drainage Act.

After completion, the existing portion of the O'Shea Drain in Concession 9 shall be maintained by the Township of Lucan Biddulph at the expense of the affected two properties in the following proportions: 65% to property Roll No. 30-102 and 35% to property Roll No. 30-103-01, until such time as the assessment is changed under the Drainage Act.

Special Assessments shall **not** be pro-rated for future maintenance purposes but shall be applied as an actual cost special if part of the maintenance.



MAINTENANCE (cont'd)

The above existing portions of the Mitchell Drain shall be maintained in accordance with the grades and dimensions set out in the plans and specifications contained in the applicable 1969 and 2003 reports. The above existing portions of the O'Shea Drain shall be maintained in accordance with the grades and dimensions set out in the plans and specifications contained in the 1977 report.

Repairs or improvements to any road culvert or sub-surface road crossing shall be the responsibility of the applicable Road Authority, entirely at their cost.

Respectfully submitted,

SPRIET ASSOCIATES LONDON LIMITED

M.P. DeVos, P. Eng.



MPD:kj



SCHEDULE 'A' - ALLOWANCES

MITCHELL & O'SHEA DRAIN 2026

Township of Lucan Biddulph

In accordance with Sections 29 and 30 of the Drainage Act, we determine the allowances payable to owners entitled thereto as follows:

CON.	LOT	ROLL NUMBER (Owner)	Section 29 Right-of-Way	Section 30 Damages	TOTALS
MITCHELL DRAIN					
7	12	30-030 (Frank A Dietrich Farms Ltd.)	\$	\$ 6,230.00	\$ 6,230.00
7	13	30-031(Hugh J Dietrich Farms Ltd.)		4,950.00	4,950.00
7	14	30-032(J. Dietrich)		790.00	790.00
NBC	Pt.13	30-098(S. Lynn)		100.00	100.00
Total Allowances			\$	\$ 12,070.00	\$ 12,070.00

TOTAL ALLOWANCES ON THE MITCHELL DRAIN **\$ 12,070.00**

O'SHEA DRAIN					
7	14	30-032(J. Dietrich)	\$	\$ 11,130.00	\$ 11,130.00
8	14	30-087(Sutom Holsteins Inc.)		5,230.00	5,230.00
8	15	30-086(SWB Poultry Farms)		7,210.00	7,210.00
9	15	30-102(Bloemen Dairy Farms Inc.)		110.00	110.00
9	Pt. 16	30-103-01(Bloemen Dairy Farms Inc.)		80.00	80.00
Total Allowances			\$	\$ 23,760.00	\$ 23,760.00

TOTAL ALLOWANCES ON THE O'SHEA DRAIN **\$ 23,760.00**

SCHEDULE 'A' - ALLOWANCES (Cont'd)

MITCHELL & O'SHEA DRAIN 2026

Township of Lucan Biddulph

CON.	LOT	ROLL NUMBER (Owner)	Section 29 Right-of-Way	Section 30 Damages	TOTALS
DRAIN 5					
7	13	30-031(Hugh J Dietrich Farms Ltd.)	\$ 6,040.00	\$ 7,380.00	\$ 13,420.00
7	14	30-032(J. Dietrich)	210.00	250.00	460.00
Total Allowances			\$ 6,250.00	\$ 7,630.00	\$ 13,880.00
TOTAL ALLOWANCES ON DRAIN 5					\$ 13,880.00
DRAIN 8					
7	11	30-029(Frank A Dietrich Farms Ltd.)	\$ 2,220.00	\$ 2,720.00	\$ 4,940.00
7	12	30-030 (Frank A Dietrich Farms Ltd.)	2,120.00	2,600.00	4,720.00
NBC	Pt.13	30-097(R. Grimminck)	20.00	80.00	100.00
Total Allowances			\$ 4,360.00	\$ 5,400.00	\$ 9,760.00
TOTAL ALLOWANCES ON DRAIN 8					\$ 9,760.00
DRAIN 9					
7	12	30-030 (Frank A Dietrich Farms Ltd.)	\$ 1,440.00	\$ 1,760.00	\$ 3,200.00
7	13	30-031(Hugh J Dietrich Farms Ltd.)	680.00	840.00	1,520.00
8	13	30-088(Three County Farms Ltd.)	20.00	2,020.00	2,040.00
Total Allowances			\$ 2,140.00	\$ 4,620.00	\$ 6,760.00
TOTAL ALLOWANCES ON DRAIN 9					\$ 6,760.00
TOTAL ALLOWANCES ON THE MITCHELL & O'SHEA DRAIN 2026					\$ 66,230.00

SCHEDULE 'B' - COST ESTIMATE

MITCHELL & O'SHEA DRAIN 2026

Township of Lucan Biddulph

We have made an estimate of the cost of the proposed work which is outlined in detail as follows:

MITCHELL DRAIN

Mobilization of equipment	\$	800.00
Installation of the following concrete field tile including supply & installation of geotextile around tile joints		
1088 meters of 750mm dia. concrete tile	\$	43,280.00
Supply of the above listed tile/pipe	\$	105,030.00
Hauling of excess material for 750mm tile (approx. 177 m ³) to locations on properties	\$	1,800.00
Contingency Allowance for stony conditions (20 pull outs)	\$	5,700.00
Contingency Allowance to install the new tile immediately adjacent to the existing tile and destroying the existing tile with a rubber tired backhoe afterwards (See General Notes on Drawings) (Approx. 76 meters)	\$	300.00
Strip, stockpile and relevel topsoil from tile trench and adjacent working area (4m wide) specified on drawings (approx. 1088m)	\$	6,500.00
Disconnect existing 675mm O'Shea Branch tile from junction box and connect new 675mm Mitchell tile including destroying approx. 12m of 675mm tile	\$	1,000.00
Sta. 0+438± Relocate existing 900mm x 1200mm DICB from west side to east side of existing junction box including coring new holes in both structures and 2m - 300mm sewer pipe lead	\$	2,200.00
Supply and install 10m - 675mm Concrete tile from existing O'Shea Br to relocated DICB	\$	1,700.00
Supply and install one 2400mm x 1200mm standard catchbasin junction box at Sta. 0+493 including benching, vent, grate, connection of new and existing tiles	\$	12,000.00

SCHEDULE 'B' - COST ESTIMATE (cont'd)**MITCHELL & O'SHEA DRAIN 2026
Township of Lucan Biddulph****MITCHELL DRAIN (cont'd)**

Supply and install one 2400mm x 1200mm standard catchbasin junction box at Sta. 0+961 including benching, connection of new and existing tiles, vent, berm with turfmat overflow chute	\$ 15,000.00
Supply and install one 1200mm x 1800mm standard catchbasin junction box at Sta. 1+526 including berm & turf mat overflow chute, grate, connection to new & exist. tiles, vent, removal and disposal of existing catchbasins	\$ 9,000.00
Exposing and locating existing tile drains	\$ 3,810.00
Tile connections, cross connection as noted on plan including fittings	\$ 3,000.00
Contract security financing	\$ 3,170.00
Tile connections and contingencies	\$ 10,000.00
Allowances under Sections 29 & 30 of the Drainage Act	\$ 12,070.00

O'SHEA DRAIN

Mobilization of equipment	\$ 1,000.00
Supply & install one 6 meter length of 900mm dia., H.D.P.E. outlet pipe including rodent gate and quarry stone rip-rap protection around pipe and end of ditch (Approximately 6m ³ quarry stone req'd)	\$ 5,430.00
Installation of the following concrete field tile including supply & installation of bedding where applicable and geotextile around tile joints	
10 meters of 525mm dia. concrete tile	\$ 310.00
456 meters of 600mm dia. concrete tile	\$ 15,440.00
670 meters of 675mm dia. concrete tile	\$ 25,290.00
86 meters of 750mm dia. concrete tile	\$ 3,420.00
175 meters of 825mm dia. concrete tile	\$ 7,850.00
175 meters of 825mm dia. concrete tile 2000D fully bedded	\$ 32,130.00
144 meters of 825mm dia. concrete tile 2000D	\$ 9,550.00
Supply of the above listed tile	\$ 167,710.00
Hauling of excess material for 750 to 825mm tile (approx.365 m ³) to Sta.0+325-0+526 and place as additional cover (Approx. 365m ³)	\$ 3,700.00

SCHEDULE 'B' - COST ESTIMATE (cont'd)**MITCHELL & O'SHEA DRAIN 2026
Township of Lucan Biddulph****O'SHEA DRAIN (cont'd)**

Contingency Allowance for stony conditions (22 pull outs)	\$	6,300.00
Contingency Allowance to install the new tile immediately adjacent to the existing tile and destroying the existing tile with a rubber tired backhoe afterwards (See General Notes on Drawings) (Approx. 1146 meters)	\$	4,000.00
Strip, stockpile and relevel topsoil from tile trench and adjacent working area (4m wide standard or wider where required) specified on drawings (approx. 1730m)	\$	10,400.00
24.0 meters of 610mm dia., 9.5mm thickness smooth wall steel pipe		
Supply	\$	7,680.00
Installation under Mitchell Line by boring	\$	16,200.00
Disconnect exist. 450mm± subsurface road crossing and fill with cement grout	\$	2,400.00
Supply and install four 900mm x 1200mm standard catchbasins including berms with Turfmat overflow chutes (2) where specified grates, leads, vents, removal and disposal of existing catchbasins	\$	16,800.00
Clearing and Grubbing	\$	6,700.00
Exposing and locating existing tile drains	\$	2,290.00
Exposing and locating existing utilities	(report)	\$ 850.00
	(construction)	\$ 850.00
Tile connections, cross connection as noted on plan including fittings	\$	1,500.00
Contract security financing	\$	5,220.00
Tile connections and contingencies	\$	8,500.00
Allowances under Sections 29 & 30 of the Drainage Act	\$	23,760.00

SCHEDULE 'B' - COST ESTIMATE (cont'd)**MITCHELL & O'SHEA DRAIN 2026
Township of Lucan Biddulph****DRAIN 5**

Mobilization of equipment	\$	300.00
Installation of the following concrete field tile including supply & installation of geotextile around tile joints		
110 meters of 200mm dia. concrete tile	\$	2,580.00
435 meters of 300mm dia. 2000-D concrete tile	\$	10,870.00
125 meters of 350mm dia. concrete tile	\$	3,250.00
Supply of the above listed tile	\$	15,590.00
Supply & Installation of the following sewer pipe (with rubber gaskets) past trees including supply, installation and compaction of bedding and backfill materials		
18 meters of 200mm dia. sewer pipe	\$	1,260.00
Supply of the above listed sewer pipe	\$	450.00
Contingency Allowance for stony conditions (6 pull outs)	\$	1,700.00
Contingency Allowance to install the new tile immediately adjacent to the existing tile and destroying the existing tile with a rubber tired backhoe afterwards (See General Notes on Drawings) (Approx. 540 meters)	\$	1,900.00
Strip, stockpile and relevel topsoil from tile trench and adjacent working area (4m wide) specified on drawings (approx. 688m)	\$	4,100.00
Supply and install one 600mm x 600mm standard on-line ditch inlet catchbasin and one 2mx3m blind inlet catchbasin including grate, lead & vent	\$	4,900.00
Clearing and Grubbing	\$	400.00
Exposing and locating existing tile drains	\$	1,400.00
Tile connections and fittings as noted on plan	\$	1,250.00
Contract security financing	\$	750.00
Tile connections and contingencies	\$	2,800.00
Allowances under Sections 29 & 30 of the Drainage Act	\$	13,880.00

SCHEDULE 'B' - COST ESTIMATE (cont'd)**MITCHELL & O'SHEA DRAIN 2026
Township of Lucan Biddulph****DRAIN 8**

Mobilization of equipment	\$	300.00
Installation of the following concrete field tile including supply & installation of geotextile around tile joints		
77 meters of 300mm dia. concrete tile	\$	1,920.00
246 meters of 400mm dia. concrete tile	\$	6,700.00
145 meters of 450mm dia. concrete tile	\$	4,170.00
Supply of the above listed tile	\$	15,530.00
Supply & Installation of the following sewer pipe (with rubber gaskets) past trees including supply, installation and compaction of bedding and backfill materials		
15 meters of 300mm dia. sewer pipe	\$	1,200.00
Supply of the above listed sewer pipe	\$	680.00
Contingency Allowance for stony conditions (6 pull outs)	\$	1,700.00
Contingency Allowance to install the new tile immediately adjacent to the existing tile and destroying the existing tile with a rubber tired backhoe afterwards (See General Notes on Drawings) (Approx. 483 meters)	\$	1,700.00
Strip, stockpile and relevel topsoil from tile trench and adjacent working area (4m wide) specified on drawings (approx. 483m)	\$	2,900.00
Supply and install one 600mm x 600mm on-line standard catchbasin and one 2mx3m blind inlet catchbasin including grate, lead & vent	\$	4,900.00
Clearing and Grubbing	\$	400.00
Exposing and locating existing tile drains	\$	1,000.00
Tile connections and fittings as noted on plan	\$	900.00
Contract security financing	\$	660.00
Tile connections and contingencies	\$	2,000.00
Allowances under Sections 29 & 30 of the Drainage Act	\$	9,760.00

SCHEDULE 'B' - COST ESTIMATE (cont'd)**MITCHELL & O'SHEA DRAIN 2026
Township of Lucan Biddulph****DRAIN 9**

Mobilization of equipment	\$	300.00
281 meters of open ditch cleanout (Approx. 140 m ³)	\$	2,250.00
Levelling of excavated material	\$	700.00
Clearing & grubbing	\$	5,100.00
Supply and install quarry stone rip-rap around existing tile outlets (3) 6m ³ req'd	\$	2,100.00
Installation of the following concrete field tile including supply & installation of geotextile around tile joints		
218 meters of 450mm dia. concrete tile	\$	6,270.00
Supply of the above listed tile	\$	8,420.00
Supply & Installation of the following sewer pipe (with rubber gaskets) past trees including supply, installation and compaction of bedding and backfill materials		
18 meters of 450mm dia. sewer pipe	\$	1,440.00
Supply of the above listed sewer pipe	\$	1,810.00
Contingency Allowance for stony conditions (3 pull outs)	\$	900.00
Contingency Allowance to install the new tile immediately adjacent to the existing tile and destroying the existing tile with a rubber tired backhoe afterwards (See General Notes on Drawings) (Approx. 236 meters)	\$	800.00
Strip, stockpile and relevel topsoil from tile trench and adjacent working area (4m wide) specified on drawings (approx. 236m)	\$	1,400.00
Supply and install one 900mm x 1200mm on-line ditch inlet catchbasin including grate, vent, removal and disposal of existing catchbasin, and quarry stone rip rap around basin (Approx. 2m ³ req'd)	\$	4,100.00
Clearing and Grubbing	\$	400.00
Exposing and locating existing tile drains (construction)	\$	500.00
Contract security financing	\$	550.00
Tile connections and contingencies	\$	2,400.00
Allowances under Sections 29 & 30 of the Drainage Act	\$	6,760.00

SCHEDULE 'B' - COST ESTIMATE (cont'd)**MITCHELL & O'SHEA DRAIN 2026
Township of Lucan Biddulph****ADMINISTRATION**

Conservation Authority Review Fee	\$	900.00
Interest and Net Harmonized Sales Tax	\$	28,850.00
Geotechnical Report and settlement monitoring (by others)	\$	36,670.00
Survey, Plan and Final Report	\$	99,357.00
Expenses	\$	2,383.00
Supervision and Final Inspection	\$	<u>39,700.00</u>
TOTAL ESTIMATED COST	\$	<u><u>999,500.00</u></u>

MITCHELL & O'SHEA DRAIN 2025

Township of Lucan Biddulph

Job No. 224185

Originally Submitted February 12, 2026
 Revised for Court of Revision April 22, 2026

* = Non-agricultural

CON.	LOT	HECTARES AFFECTED	ROLL No. (OWNER)	63.5mm INCREASE	BENEFIT	OUTLET	TOTAL
MITCHELL & O'SHEA DRAINS - LOWER PORTION							
7	11	11.2	30-029(Frank A Dietrich Farms Ltd		\$	\$ 1,483.00	\$ 1,483.00
7	12	26.8	30-030 (Frank A Dietrich Farms Ltd.)			3,520.00	3,520.00
7	13	40.5	30-031(Hugh J Dietrich Farms Ltd.)			5,165.00	5,165.00
7	14	35.7	30-032(J. Dietrich)	25,167.00	91,410.00	3,641.00	120,218.00
NBC	Pt.13	4.8	30-097(R. Grimminck)			422.00	422.00
NBC	Pt.13	26.5	30-098(S. Lynn)			3,358.00	3,358.00
NBC	Pt.14	16.8	30-096(L. & S. Lynn)			2,193.00	2,193.00
* NBC	Pt.14	4.0	30-093(D. & J. Richardson)			433.00	433.00
8	13	40.5	30-088(Three County Farms Ltd.)			4,387.00	4,387.00
8	14	39.9	30-087(Sutom Holsteins Inc.)			2,535.00	2,535.00
* 8	Pt.14	1.0	30-087-02 (A. Verhoog)			149.00	149.00
8	15	25.3	30-086(SWB Poultry Farms)	6,217.00		3,398.00	9,615.00
* 8	Pt. 15	2.4	30-086-01(L. Bilcke)			361.00	361.00
8	16	1.9	30-085(H. & S. Damen)	472.00		257.00	729.00
NBC	15	37.1	30-089(E. & B. French)			3,588.00	3,588.00
NBC	16	2.8	40-066(E. & B. French)			190.00	190.00
9	15	29.8	30-102(Bloemen Dairy Farms Inc.)	7,395.00		4,035.00	11,430.00
* 9	16	0.42	30-103(M. & D. Buchner)			85.00	85.00
9	Pt. 16	23.6	30-103-01(Bloemen Dairy Farms Inc.)	5,733.00		3,128.00	8,861.00
* 9	Pt. 16	0.79	30-103-11(J. Damen)			134.00	134.00
TOTAL ASSESSMENT ON LANDS				\$ 44,984.00	\$ 91,410.00	\$ 42,462.00	\$ 178,856.00
Moorseville Dr	0.4		Township of Lucan Biddulph	297.00	\$	\$ 162.00	\$ 459.00
Roman Line	0.4		Township of Lucan Biddulph			162.00	162.00
Mitchell Line	4.4		Ontario Ministry of Transportation	1,489.00		2,234.00	3,723.00
TOTAL ASSESSMENT ON ROADS				\$ 1,786.00	\$	\$ 2,558.00	\$ 4,344.00
TOTAL ASSESSMENT ON THE MITCHELL & O'SHEA DRAINS - LOWER PORTION							\$ 183,200.00

SCHEDULE 'C' - ASSESSMENT FOR CONSTRUCTION (cont'd)

MITCHELL & O'SHEA DRAIN 2026

Township of Lucan Biddulph

Job No. 224185

Submitted February 12, 2026
 Revised for Court of Revision April 22, 2026

* = *Non-agricultural*

CON.	LOT	HECTARES AFFECTED	ROLL No. (OWNER)	BENEFIT	OUTLET	TOTAL		
MITCHELL DRAIN								
7	11	11.2	30-029(Frank A Dietrich Farms Ltd.)	\$	\$ 6,875.00	\$ 6,875.00		
7	12	26.8	30-030 (Frank A Dietrich Farms Ltd.)	73,620.00	11,602.00	85,222.00		
7	13	40.5	30-031(Hugh J Dietrich Farms Ltd.)	58,530.00	6,378.00	64,908.00		
7	14	35.7	30-032(J. Dietrich)	9,370.00	643.00	10,013.00		
NBC	Pt.13	4.8	30-097(R. Grimminck)		2,045.00	2,045.00		
NBC	Pt.13	26.5	30-098(S. Lynn)	2,680.00	16,901.00	19,581.00		
NBC	Pt.14	16.8	30-096(L. & S. Lynn)		11,194.00	11,194.00		
* NBC	Pt.14	4.0	30-093(D. & J. Richardson)		2,211.00	2,211.00		
8	13	40.5	30-088(Three County Farms Ltd.)		25,926.00	25,926.00		
8	14	23.4	30-087(Sutom Holsteins Inc.)		15,637.00	15,637.00		
* 8	Pt.14	1.0	30-087-02 (A. Verhoog)		760.00	760.00		
NBC	15	37.1	30-089(E. & B. French)		18,380.00	18,380.00		
NBC	16	2.8	40-066(E. & B. French)		967.00	967.00		
TOTAL ASSESSMENT ON LANDS				\$	144,200.00	\$ 119,519.00	\$ 263,719.00	
Roman Line					0.4	Township of Lucan Biddulph	\$ 76.00	\$ 76.00
Mitchell Line					4.4	Ontario Ministry of Transportation	7,255.00	7,255.00
TOTAL ASSESSMENT ON ROADS				\$		\$ 7,331.00	\$ 7,331.00	
TOTAL ASSESSMENT ON THE MITCHELL DRAIN						\$ <u>271,050.00</u>		

SCHEDULE 'C' - ASSESSMENT FOR CONSTRUCTION (Cont'd)

MITCHELL & O'SHEA DRAIN 2026

Township of Lucan Biddulph

* = Non-agricultural

CON.	LOT	HECTARES AFFECTED	ROLL No. (OWNER)	51mm INCREASE	BENEFIT	OUTLET	TOTAL
O'SHEA DRAIN							
7	14	10.8	30-032(J. Dietrich)	\$	\$	\$ 1,886.00	\$ 1,886.00
8	14	16.5	30-087(Sutom Holsteins Inc.)		31,540.00	7,568.00	39,108.00
8	15	25.3	30-086(SWB Poultry Farms)	7,953.00	52,990.00	24,555.00	85,498.00
*	8	Pt. 15	2.43 30-086-01(L. Bilcke)			3,117.00	3,117.00
8	16	1.9	30-085(H. & S. Damen)	185.00		2,564.00	2,749.00
9	15	29.8	30-102(Bloemen Dairy Farms Inc.)	3,751.00	13,910.00	43,813.00	61,474.00
*	9	16	0.4 30-103(M. & D. Buchner)			926.00	926.00
9	Pt. 16	23.6	30-103-01(Bloemen Dairy Farms Inc)	2,505.00	550.00	33,963.00	37,018.00
*	9	Pt. 16	0.80 30-103-11(J. Damen)			1,410.00	1,410.00
TOTAL ASSESSMENT ON LANDS				\$ 14,394.00	\$ 98,990.00	\$ 119,802.00	\$ 233,186.00
=====							
Moorseville Dr	0.4	Township of Lucan Biddulph		\$ 118.00	\$	\$ 1,619.00	\$ 1,737.00
Mitchell Line	1.6	Ontario Ministry of Transportation		618.00	6,390.00	8,459.00	15,467.00
TOTAL ASSESSMENT ON ROADS				\$ 736.00	\$ 6,390.00	\$ 10,078.00	\$ 17,204.00
=====							
SPECIAL ASSESSMENT against the Ministry of Transportation for the increased cost of boring a 610mm smooth wall steel pipe under Mitchell Line (Hwy 23)							\$ 75,590.00
SPECIAL ASSESSMENT against the Quadro for the increased cost of locating and exposing their fibre optic cables on Mitchell Line							\$ 2,410.00
TOTAL ASSESSMENT ON THE O'SHEA DRAIN							\$ 328,390.00
=====							
DRAIN 5							
7	13	12.4	30-031(Hugh J Dietrich Farms Ltd.)	\$ 1,212.00	\$ 56,830.00	\$ 24,086.00	\$ 82,128.00
7	14	4.6	30-032(J. Dietrich)	58.00		3,855.00	3,913.00
8	13	0.2	30-088(Three County Farms Ltd.)	4.00		239.00	243.00
8	14	0.9	30-087(Sutom Holsteins Inc.)	36.00		2,420.00	2,456.00
TOTAL ASSESSMENT ON LANDS				\$ 1,310.00	\$ 56,830.00	\$ 30,600.00	\$ 88,740.00
=====							
TOTAL ASSESSMENT ON DRAIN 5							\$ 88,740.00
=====							

SCHEDULE 'C' - ASSESSMENT FOR CONSTRUCTION (Cont'd)

MITCHELL & O'SHEA DRAIN 2026

Township of Lucan Biddulph

Originally Submitted February 12, 2026
 Revised for Court of Revision April 22, 2026

* = *Non-agricultural*

CON.	LOT	HECTARES AFFECTED	ROLL No. (OWNER)	BENEFIT	OUTLET	TOTAL
DRAIN 8						
7	11	9.8	30-029(Frank A Dietrich Farms Ltd.)	\$ 19,860.00	\$ 18,901.00	\$ 38,761.00
7	12	2.5	30-030 (Frank A Dietrich Farms Ltd.)	18,980.00	1,688.00	20,668.00
NBC	Pt.13	4.8	30-097(R. Grimminck)		4,605.00	4,605.00
NBC	Pt.13	5.1	30-098(S. Lynn)		6,586.00	6,586.00
TOTAL ASSESSMENT ON LANDS				\$ 38,840.00	\$ 31,780.00	\$ 70,620.00
TOTAL ASSESSMENT ON DRAIN 8						\$ <u>70,620.00</u>
DRAIN 9						
7	12	1.1	30-030 (Frank A Dietrich Farms Ltd.)	12,800.00	400.00	13,200.00
7	13	2.5	30-031(Hugh J Dietrich Farms Ltd.)	7,900.00	1,768.00	9,668.00
8	13	13.0	30-088(Three County Farms Ltd.)	10,070.00	11,228.00	21,298.00
8	14	11.2	30-087(Sutom Holsteins Inc.)		13,334.00	13,334.00
TOTAL ASSESSMENT ON LANDS				\$ 30,770.00	\$ 26,730.00	\$ 57,500.00
TOTAL ASSESSMENT ON DRAIN 9						\$ <u>57,500.00</u>
TOTAL ASSESSMENT ON THE MITCHELL & O'SHEA DRAIN 2026						\$ <u>999,500.00</u>

SCHEDULE OF NET ASSESSMENT

MITCHELL & O'SHEA DRAIN 2026

Township of Lucan Biddulph

Job No. 224185

Originally Submitted February 12, 2026
Revised for Court of Revision April 22, 2026

* = Non-agricultural

ROLL NUMBER (OWNER)	TOTAL GRANTABLE ASSESSMENT	GRANT	INCREASE		APPROX. NET
			OVER 38mm DESIGN ASSESSMENT	ALLOWANCES	
30-029(Frank A Dietrich Farms Ltd.)	\$ 47,119.00	\$ 15,706.00	\$	\$ 4,940.00	\$ 26,473.00
30-030 (Frank A Dietrich Farms Ltd.)	122,610.00	40,870.00		14,150.00	67,590.00
30-031(Hugh J Dietrich Farms Ltd.)	160,657.00	53,552.00	1,212.00	19,890.00	88,427.00
30-032(J. Dietrich)	110,805.00	36,935.00	25,225.00	12,380.00	86,715.00
30-097(R. Grimminck)	7,072.00	2,357.00		100.00	4,615.00
30-098(S. Lynn)	29,525.00	9,842.00		100.00	19,583.00
30-096(L. & S. Lynn)	13,387.00	4,462.00			8,925.00
* 30-093(D. & J. Richardson)	2,644.00				2,644.00
30-088(Three County Farms Ltd.)	51,850.00	17,283.00	4.00	2,040.00	32,531.00
30-087(Sutom Holsteins Inc.)	73,034.00	24,345.00	36.00	5,230.00	43,495.00
* 30-087-02 (A. Verhoog)	909.00				909.00
30-086(SWB Poultry Farms)	80,943.00	26,981.00	14,170.00	7,210.00	60,922.00
* 30-086-01(L. Bilcke)	3,478.00				3,478.00
30-085(H. & S. Damen)	2,821.00	940.00	657.00		2,538.00
30-089(E. & B. French)	21,968.00	7,323.00			14,645.00
40-066(E. & B. French)	1,157.00	386.00			771.00
30-102(Bloemen Dairy Farms Inc.)	61,758.00	20,586.00	11,146.00	110.00	52,208.00
* 30-103(M. & D. Buchner)	1,011.00				1,011.00
30-103-01(Bloemen Dairy Farms Inc.)	37,641.00	12,547.00	8,238.00	80.00	33,252.00
* 30-103-11(J. Damen)	1,544.00				1,544.00
Moorseville Dr	\$ 1,781.00	\$	\$ 415.00	\$	\$ 2,196.00
Roman Line	238.00				238.00
Mitchell Line	24,338.00		2,107.00		26,445.00
<u>Non Prorated Special Assessment</u>					
Mitchell Line - Boring	75,590.00				75,590.00
Quadro	2,410.00				2,410.00
<hr/>					
\$ 936,290.00 \$ 274,115.00 \$ 63,210.00 \$ 66,230.00 \$ 659,155.00					
<hr/>					
TOTAL NON-GRANTABLE ASSESSMENT	\$ 63,210.00				
TOAL PROJECT COST	\$ 999,500.00				

**SPECIFICATIONS FOR CONSTRUCTION
OF
MUNICIPAL DRAINAGE WORKS**

G E N E R A L I N D E X

SECTION A	General Work	Pages 1 to 6
SECTION B	Open Drain	Pages 7 to 9
SECTION C	Tile Drain	Pages 10 to 15
STANDARD DETAILED DRAWINGS		SDD-01 to SDD-05



SECTION A - GENERAL WORK

INDEX

<u>SECTION NUMBER</u>	<u>PAGE NO.</u>
A.1 COMMENCEMENT AND COMPLETION OF WORK.....	1
A.2 WORKING AREA AND ACCESS.....	1
A.3 ROAD CROSSINGS.....	1
A.4 SURPLUS EXCAVATED MATERIAL AND GRAVEL.....	3
A.5 FENCES.....	3
A.6 LIVESTOCK.....	4
A.7 STANDING CROPS.....	4
A.8 RAILWAYS, HIGHWAYS, UTILITIES.....	4
A.9 LOCATION OF UTILITIES.....	4
A.10 IRON BARS.....	4
A.11 STAKES.....	4
A.12 RIP-RAP.....	5
A.13 GABION BASKETS.....	5
A.14 RESTORATION OF LAWNS.....	5
A.15 RESTORATION OF ROADS AND LANEWAYS.....	6

SECTION A

GENERAL WORK

A.1 COMMENCEMENT AND COMPLETION OF WORK

The work must commence immediately after the Contractor is notified of the acceptance of his tender or at a later date, if set out as a condition of the tender. If weather creates poor ground or working conditions the Contractor may be required, at the discretion of the Engineer, to postpone or halt work until conditions become acceptable.

As noted on the drawn, the contractor must first arrange for a preconstruction meeting to be held on the site with the Contractor and affected owners attending to review in detail the construction scheduling, access and other pertinent details. The Contractor's costs for attending this meeting shall be included in his lump sum tender price. If the Contractor leaves the job site for a period of time after initiation of work, he shall give the Engineer and the Superintendent a minimum of twenty-four (24) hours' notice prior to returning to the project.

The work must be proceeded with in such a manner as to ensure its completion at the earliest possible date and within the time limit set out in the tender or in the contract documents.

A.2 WORKING AREA AND ACCESS

The working area available to the Contractor to construct the drain and related works including an access route to the drain shall be as specified on the drawings.

Should the specified widths become inadequate due to unusual conditions, the Contractor shall notify the Engineer immediately in order that negotiations with the affected owners can take place.

Where a Contractor exceeds the specified widths due to the nature of his operations and without authorization, he shall be held responsible for the costs of all additional damages and the amount shall be deducted from his contract price and paid to the affected owners by the Municipality.

A.3 ROAD CROSSINGS

.1 General

- .1 **Scope**: These specifications apply to all road crossings - Municipal, County, Regional, or Highway Roads. Where the word "Authority" is used, it shall be deemed to apply to the appropriate owning authority. These specifications in no way limit the Authority's Specifications and Regulations governing the construction of drains on their Road Allowance. The Authority will supply no labour, equipment or materials for the construction of the road crossing unless otherwise noted on the drawings.
- .2 **Road Occupancy Permit**: Where applicable the Contractor must submit an Application for a Road Occupancy Permit to the Authority and allow a minimum of 5 working days (exclusive of holidays) for its review and issuance.
- .3 **Road Closure Request and Construction Notification**: The Contractor shall submit written notification of construction and request for road closure (if applicable) to the Road Authority/Public Works Manager and the Drainage Engineer or Superintendent for review and approval a minimum of five (5) working days (exclusive of holidays) prior to proceeding with any work on road allowance. It shall be the Road Authority's responsibility to notify all the applicable emergency services, schools, etc. of the road closure or construction taking place.
- .4 **Traffic Control**: Where the Contractor is permitted to close the road to through traffic, the Contractor shall provide for and adequately sign the detour route to the satisfaction of the Road Authority. Otherwise, the Contractor shall keep the road open to traffic at all times. The Contractor shall provide, for the supply, erection and maintenance, suitable warning signs and/or flagmen in accordance with the Manual of Uniform Traffic Control Devices and to the satisfaction of the Road Authority to notify the motorists of work on the road ahead.

A.3 **ROAD CROSSINGS** (cont'd)

- .5 **Site Meeting/Inspection**: A site meeting shall be held with the affected parties to review in detail the crossing and/or its related works. The Authority's Inspector and/or the Drainage Engineer will inspect the work while in progress to ensure that the work is done in strict accordance with the specifications.
- .6 **Weather**: No construction shall take place during inclement weather or periods of poor visibility.
- .7 **Equipment**: No construction material and/or equipment is to be left within 3 meters of the edge of pavement overnight or during periods of inclement weather.

.2 **Jacking and Boring**

- .1 **Material**: The bore pipe shall consist of new, smooth wall steel pipe, meeting the requirements of H20 loading for road crossings and E80 loading for railway crossings. The minimum size, wall thickness and length shall be as shown on the drawings. Where welding is required, the entire circumference of any joint shall be welded using currently accepted welding practices.
- .2 **Site Preparation and Excavation**: Where necessary, fences shall be carefully taken down as specified in the General Conditions. Prior to any excavation taking place, all areas which will be disturbed shall be stripped of topsoil. The topsoil is to be stockpiled in locations away from the bore operation, off the line of future tile placement and out of existing water runs or ditches. The bore pit shall be located at the upstream end of the bore unless otherwise specified or approved. Bore pits shall be kept back at least 1 meter from the edge of pavement and where bore pits are made in any portion of the shoulder, the excavated material shall be disposed of off the road allowance and the pit backfilled with thoroughly compacted Granular "A" for its entire depth.
- .3 **Installation**: The pipe shall be installed in specified line and grade by a combination of jacking and boring. Upon completion of the operations, both ends of the bore pipe shall be left uncovered until the elevation has been confirmed by the Engineer or Superintendent. The ends of the bore pipe shall be securely blocked off and the location marked by means of a stake extending from the pipe invert to 300mm above the surrounding ground surface.
- .4 **Unstable Soil or Rock**: The Contractor shall contact the Engineer immediately should unstable soil be encountered or if boulders of sufficient size and number to warrant concern are encountered. Any bore pipe partially installed shall be left in place until alternative methods or techniques are determined by the Engineer after consultation with the Contractor, the Superintendent and the owning authority.
- .5 **Tile Connections**: Prior to commencement of backfilling, all tile encountered in excavations shall be reconnected using material of a size comparable to the existing material. Where the excavation is below the tile grade, a compacted granular base is to be placed prior to laying the tile. Payment for each connection will be made at the rate outlined in the Form of Tender and Agreement.
- .6 **Backfill**: Unless otherwise specified, the area below the proposed grade shall be backfilled with a crushed stone bedding. Bore pits and excavations outside of the shoulder area may be backfilled with native material compacted to a density of 95% Standard Proctor. All disturbed areas shall be neatly shaped, have the topsoil replaced and hand seeded. Surplus material from the boring operation shall be removed from the site at the Contractor's expense.
- .7 **Restoration**: The entire affected area shall be shaped and graded to original lines and grades, the topsoil replaced, and the area seeded down at the rate of 85 kg/per ha. unless otherwise specified or in accordance with the M.T.O. Encroachment Permit. Fences shall be restored to their original condition in accordance with the General Conditions.
- .8 **Acceptance**: All work undertaken by the Contractor shall be to the satisfaction of the Engineer.

A.3 **ROAD CROSSINGS** (cont'd)

.3 **Open Cut**

- .1 **Material**: The culvert or sub-drain crossing pipe material shall be specified on the drawings.
- .2 **Site Preparation and Excavation**: Where necessary, fences shall be carefully taken down as specified in the general conditions. Prior to any excavation taking place, the areas which will be disturbed shall be stripped of topsoil. The topsoil is to be stockpiled in locations away from the construction area.
- .3 **Installation**: The pipe shall be installed using bedding and cover material in accordance with Standard Detailed Drawing No. 2 or detail provided on drawings.
- .4 **Unstable Soil or Rock**: The Contractor shall contact the Engineer immediately should unstable soil be encountered or if boulders of sufficient size and number to warrant concern are encountered.
- .5 **Tile Connections**: Prior to commencement of backfilling, all tiles encountered in excavations shall be reconnected using material of a size comparable to the existing material. Where the excavation is below the tile grade, a compacted granular base is to be placed prior to laying the tile. Payment for connections not shown on the drawings shall be an extra to the contract.
- .6 **Backfill**: Backfill from the top of the cover material up to the underside of road base shall meet the requirements for M.T.O. Granular "B". The backfill shall be placed in lifts not exceeding 300mm in thickness and each lift shall be thoroughly compacted to produce a density of 98% Standard Proctor. Granular "B" road base for County Roads and Highways shall be placed to a 450mm thickness and Granular "A" shall be placed to a thickness of 200mm, both meeting M.T.O. requirements. Granular road base materials shall be thoroughly compacted to produce a density of 100% Standard Proctor.

Where the road surface is paved, the Contractor shall be responsible for placing an HL-4 Hot Mix Asphalt patch of the same thickness as the existing pavement. The asphalt patch shall be flush with the existing roadway on each side and not overlap. If specified, the asphalt patch shall not be placed immediately over the road base and the Granular "A" shall be brought up flush with the existing asphalt and a liberal amount of calcium chloride shall be spread on the gravel surface. The asphalt patch must be completed within the time period set out on the drawing.

The excavated material from the trench beyond a point 2.5 meters from the travelled portion or beyond the outside edge of the gravel shoulder, may be used as backfill in the trench in the case of covered drains. This material should be compacted in layers not exceeding 600mm.

A.4 **SURPLUS EXCAVATED MATERIAL AND GRAVEL**

Excess excavated material from open cut installation through roads, railways, laneways and lawn/grass areas, shall be removed and disposed of off-site by the Contractor as part of their lump sum installation price. If as a result of any work, gravel or crushed stone is required and not all the gravel or crushed stone is used in the construction of the works, the Contractor shall haul away such surplus gravel or stone unless otherwise approved.

A.5 **FENCES**

No earth shall be placed against fences and all fences removed by the Contractor are to be replaced by him in as good condition as found. In general, the Contractor will not be allowed to cut existing fences but shall disconnect existing fences at the nearest anchor post or other such fixed joint and shall carefully roll it back out of the way. Where the distance to the closest anchor post or fixed joint exceeds 50 meters, the Contractor will be allowed to cut and splice in accordance with accepted methods and to the satisfaction of the owner and the Engineer or Superintendent. Where existing fences are deteriorated to the extent that existing materials are not salvageable for replacement, the Contractor shall notify the Engineer or the Superintendent prior to dismantling. Fences damaged beyond salvaging by the Contractor's negligence shall be replaced with new materials, similar to those existing, at the Contractor's expense. The replacement of the fences shall be done to the satisfaction of the owner and the Engineer or Superintendent. The site examination should indicate to the Contractor such work, if any, and an allowance should be made in the tendered price.

The Contractor shall not leave any fence open when he is not at work in the immediate vicinity.

A.6 **LIVESTOCK**

The Contractor shall provide each property owner with 48 hours' notice prior to removing any fences along fields which could possibly contain livestock. Thereafter, the property owner shall be responsible to keep all livestock clear of the construction areas until further notified. Where necessary, the Contractor will be directed to erect temporary fences. The Contractor shall be held responsible for loss or injury to livestock or damage caused by livestock, where the injury or damage is caused by his failure to notify the property owner or through negligence or carelessness on the part of the Contractor.

The Contractor constructing a tile drain shall not be held responsible for damages or injury to livestock occasioned by leaving trenches open for inspection by the Engineer if he notifies the owner at least 48 hours prior to commencement of the work on that portion. The Contractor will be held liable for such damages or injury if the backfilling of such trenches is delayed more than 1 day after acceptance by the Engineer.

A.7 **STANDING CROPS**

The Contractor shall not be held responsible for damages to standing crops within the working area available and the access route provided if he notifies the owner thereof at least 48 hours prior to commencement of the work on that portion.

A.8 **RAILWAYS, HIGHWAYS, UTILITIES**

A minimum of forty-eight (48) hours' notice to Railways, Highways and Utilities, exclusive of Saturdays, Sundays and Holidays, shall be required by the Contractor prior to any work being performed and in the case of a pipe being installed by open cutting or boring under a Highway or Railway, a minimum of 72 hours' notice is required.

A.9 **UTILITIES**

The attention of the Contractor is drawn to the presence of utilities along the course of the drain. The Contractor will be responsible for determining the location of all utilities and will be held liable for any damage to all utilities caused by his operations. The Contractor shall co-operate with all authorities to ensure that all utilities are protected from damage during the performance of the work. The cost of any necessary relocation work shall be borne by the utility. No allowance or claims of any nature will be allowed on account for delays or inconveniences due to utilities relocation, or for inconveniences and delays caused by working around or with existing utilities not relocated.

A.10 **IRON BARS**

The Contractor shall be held liable for the cost of an Ontario Land Surveyor to replace any iron bars destroyed during the course of construction.

A.11 **STAKES**

At the time of the survey, stakes are set along the course of the drain at intervals of 50 meters. The Contractor shall ensure that the stakes are not disturbed unless approval is obtained from the Engineer. Any stakes removed by the Contractor without the authority of the Engineer, shall be replaced at the expense of the Contractor. At the request of the Contractor, any stakes which are removed or disturbed by others or by livestock, shall be replaced at the expense of the drain.

A.12 **RIP-RAP**

Rip-rap shall be specified on the drawings and shall conform to the following:

- .1 **Quarry Stone**: shall range in size from 150mm to 300mm evenly distributed and shall be placed to a 300mm thickness on a filter blanket at a 1.5 to 1 slope unless otherwise noted. Filter blanket to be Mirafi 160N or approved equal.
- .2 **Broken Concrete**: may be used in areas outside of regular flows if first broken in maximum 450mm sized pieces and mixed to blend with quarry stone as above. No exposed reinforcing steel shall be permitted.
- .3 **Shot Rock**: shall range in size from 150mm to 600mm placed to a depth of 450mm thickness on a filter blanket at a 1.5:1 slope unless otherwise noted. Filter blanket to be Mirafi 160N or approved equal.

A.13 **GABION BASKETS**

Supply and install gabion basket rip-rap protection as shown on the drawings.

Gabion baskets shall be as manufactured by Maccaferri Gabions of Canada Ltd. or approved equal and shall be assembled and installed in strict accordance with the manufacturer's recommendations.

The gabion fill material shall consist solely of fractured field stone or gabion stone graded in size from 100mm to 200mm (4" to 8") and shall be free of undersized fragments and unsuitable material.

A.14 **RESTORATION OF LAWNS**

- .1 **General**: Areas noted on the drawings to be restored with seeding or sodding shall conform to this specification, and the Contractor shall allow for all costs in his lump sum bid for the following works.
- .2 **Topsoil**: Prior to excavation, the working area shall be stripped of existing topsoil. The topsoil stockpile shall be located so as to prevent contamination with material excavated from the trench. Upon completion of backfilling operations, topsoil shall be spread over the working area to a depth equal to that which previously existed but not less than the following:
 - Seeding and sodding - minimum depth of 100mm
 - Gardens - minimum depth of 300mmIn all cases where a shortfall of topsoil occurs, whether due to lack of sufficient original depth or rejection of stockpiled material due to Contractor's operations, imported topsoil from acceptable sources shall be imported at the Contractor's expense to provide the specified depths. Topsoil shall be uniformly spread, graded, and cultivated prior to seeding or sodding. All clods or lumps shall be pulverized, and any roots or foreign matter shall be raked up and removed as directed.

.3 **Sodding**

- .1 **Materials**: Nursery sod to be supplied by the Contractor shall meet the current requirements of the Ontario Sod Growers Association for No. 1 Bluegrass Fescue Sod.
- .2 **Fertilizer**: Prior to sod placement, approved fertilizer shall be spread at the rate of 5kg/100m² of surface area and shall be incorporated into such surfaces by raking, discing or harrowing. All surfaces on which sod is to be placed shall be loose at the time of placing sod to a depth of 25mm.
- .3 **Placing Sod**: Sod shall be laid lengthwise across the face of slopes with ends close together. Sod shall be counter sunk along the joints between the existing grade and the new sodding to allow for the free flow of water across the joint. Joints in adjacent rows shall be staggered and all joints shall be pounded and rolled to a uniform surface.

On slopes steeper than 3 to 1, and in unstable areas, the Engineer may direct the Contractor to stake sod and/or provide an approved mesh to prevent slippages. In all cases where such additional work is required, it will be deemed an extra to the contract and shall be paid for in accordance with the General Conditions. No sod shall be laid when frozen nor upon frozen ground nor under any other condition not favourable to the growth of the sod. Upon completion of sod laying the Contractor shall thoroughly soak the area with water to a depth of 50mm. Thereafter it will be the responsibility of the property owner to maintain the area in a manner so as to promote growth.

A.14 **RESTORATION OF LAWNS (cont'd)**

.4 **Seeding:** Seed to be supplied by the Contractor shall be “high quality grass seed” harvested during the previous year, and shall be supplied to the project in the supplier’s original bags on which a tag setting out the following information is affixed:

- Year or Harvest - recommended rate of application
- Type of Mixture - fertilizer requirements

Placement of seed shall be by means of an approved mechanical spreader. All areas on which seed is to be placed shall be loose at the time of placing seed, to a depth of 25mm. Seed and fertilizer shall be spread in accordance with the supplier’s recommendations unless otherwise directed by the Engineer. Thereafter it will be the responsibility of the property owner to maintain the area in a manner so as to promote growth.

.5 **Settlement:** The Contractor shall be responsible during the one-year guarantee period for the necessary repair of restored areas due to trench settlement. Areas where settlement does not exceed 50mm may be repaired by top dressing with fine topsoil. In areas where settlement exceeds 50mm, the Contractor will be required to backfill the area with topsoil and restore with seeding and/or sodding as originally specified.

A.15 **RESTORATION OF ROADS AND LANEWAYS**

.1 **Gravel:** Restoration shall be in accordance with the applicable standard detailed drawing or as shown on the drawings.

.2 **Asphalt and Tar and Chip:** Prior to restoration all joints shall be neatly sawcut. Restoration shall be as a in gravel above with the addition of the following:

- .1 Roads shall have the finished grade of Granular ‘A’, allow two courses of hot-mix asphalt (M.T.O. 310), 80mm HL6 and 40mm HL3 or to such greater thickness as may be required to match the existing.
- .2 Laneways shall have the finished grade of Granular ‘A’ allow one 50mm minimum course of hot-mix asphalt (HL3) or greater as may be required to match existing.

SECTION B - OPEN DRAIN

INDEX

<u>SECTION NUMBER</u>		<u>PAGE NO.</u>
B.1	PROFILE.....	7
B.2	ALIGNMENT.....	7
B.3	CLEARING AND GRUBBING.....	7
B.4	EXCAVATION.....	7
B.5	EXCAVATED MATERIAL.....	7
B.6	EXCAVATION THROUGH BRIDGES AND CULVERTS.....	8
B.7	PIPE CULVERT.....	8
B.8	MOVING DRAINS OFF ROADS.....	8
B.9	TRIBUTARY OUTLETS.....	8
B.10	SEDIMENT BASINS AND TRAPS.....	9
B.11	SEEDING.....	9

SECTION B
OPEN DRAIN

B.1 PROFILE

The profile drawing shows the depth of cuts from the ground beside the stake to the final invert of the ditch in meters and decimals of a meter and also the approximate depth of cuts from the existing bottom of the ditch to the elevation of the ditch bottom. These cuts are established for the convenience of the Contractor; however, benchmarks will govern the final elevation of the drain. Benchmarks have been established along the course of the drain and their locations and elevations are noted on the profile drawing. A uniform grade shall be maintained between stakes in accordance with the profile drawing.

B.2 ALIGNMENT

The drain shall be constructed in a straight line and shall follow the course of the present drain or water run unless otherwise noted on the drawings. Where it is necessary to straighten any bends or irregularities in alignment not noted on the drawings, the Contractor shall contact the Engineer or Superintendent before commencing the work.

B.3 CLEARING AND GRUBBING

Prior to commencement of work, all trees, scrub, fallen timber and debris shall be removed from the side slopes of the ditch and for such a distance on the working side so as to eliminate any interference with the construction of the drain or the spreading of the spoil. The side slopes shall be neatly cut and cleared flush with slope whether or not they are affected directly by the excavation. With the exception of large stumps causing damage to the drain, the side slope shall not be grubbed. All other cleared areas shall be grubbed and the stumps put into piles for disposal by the owner.

All trees or limbs 150mm (6") or larger, that it is necessary to remove, shall be considered as logs and shall be cut and trimmed, and left in the working width separate from the brush, for use or disposal by the owner. Trees or limbs less than 150mm in diameter shall be cut in lengths not greater than 5 meters and placed in separate piles with stumps spaced not less than 75 meters apart in the working width, for the use or disposal of the owner. In all cases, these piles shall be placed clear of excavated materials, and not be piled against standing trees. No windrowing will be permitted. The clearing and grubbing and construction of the drain are to be carried out in two separate operations and not simultaneously at the same location.

B.4 EXCAVATION

The bottom width and the side slopes of the ditch shall be those shown on the profile drawing.

Unless otherwise specified on the drawings, only the existing ditch bottom is to be cleaned out and the side slopes are not to be disturbed. Where existing side slopes become unstable because of construction, the Contractor shall immediately contact the Engineer or Superintendent. Alternative methods of construction and/or methods of protection will then be determined, prior to continuing the work.

Where an existing drain is being relocated or where a new drain is being constructed, the Contractor shall, unless otherwise specified, strip the topsoil for the full width of the drain, including the location of the spoil pile. Upon completion of levelling, the topsoil shall be spread to an even depth across the full width of the spoil.

B.5 EXCAVATED MATERIAL

Excavated material shall be deposited on either or both sides of the drain as indicated on the drawings or as directed by the Engineer or Superintendent. A buffer strip of not less than 3 meters in width through farmed lands and 2 meters in width through bush areas shall be left along the top edges of the drain. The buffer strip shall be seeded and/or incorporated as specified on the drawings. The material shall be deposited beyond the specified buffer strip.

B.5 EXCAVATED MATERIAL (cont'd)

No excavated material shall be placed in tributary drains, depressions, or low areas which direct water into the ditch so that water will be trapped behind the spoil bank. The excavated material shall be placed and levelled to a minimum width to depth ratio of 50 to 1 unless instructed otherwise. The edge of the spoil bank away from the ditch shall be feathered down to the existing ground; the edge of the spoil bank nearest the ditch shall have a maximum slope of 2 to 1. The material shall be levelled such that it may be cultivated with ordinary farm equipment without causing undue hardship on machinery and personnel. No excavated material shall cover any logs, scrub, debris, etc. of any kind.

Where it is necessary to straighten any unnecessary bends or irregularities in the alignment of the ditch, the excavated material from the new cut shall be used for backfilling the original ditch. Regardless of the distance between the new ditch and the old ditch no extra compensation will be allowed for this work and must be included in the Contractor's lump sum price for the open work.

Any stones 150mm or larger left exposed on top of the levelled excavated material shall be removed and disposed of as an extra to the contract unless otherwise noted on plans.

B.6 EXCAVATION THROUGH BRIDGES AND CULVERTS

The Contractor shall excavate the drain to the full specified depth and width under all bridges. Where the bridge or culvert pipe is located within a road allowance, the excavated material shall be levelled within the road allowance. Care shall be taken not to adversely affect existing drainage patterns. Temporary bridges may be carefully removed and left on the bank of the drain but shall be replaced by the Contractor when the excavation is completed unless otherwise specified. Permanent bridges must be left intact. All necessary care and precautions shall be taken to protect the structure. The Contractor shall notify the Engineer or Superintendent if excavation may cause the structure to undermine or collapse.

B.7 PIPE CULVERTS

Where specified on the drawings, the existing culvert shall be carefully removed, salvaged and either left at the site for the owner or reinstalled at a new grade or location. The value of any damage caused to the culvert due to the Contractor's negligence in salvage operation will be determined and deducted from the contract price.

All pipe culverts shall be installed in accordance with the standard detail drawings as noted on the drawings. If couplers are required, 5 corrugation couplers shall be used for up to and including 1200mm dia. pipe and 10 corrugation couplers for greater than 1200mm dia.

B.8 MOVING DRAINS OFF ROADS

Where an open drain is being removed from a road allowance, it must be reconstructed wholly on the adjacent lands with a minimum distance of 2.0 meters between the property line and the top of the bank, unless otherwise noted on the drawings. The excavated material shall be used to fill the existing open ditch and any excess excavated material shall be placed and levelled on the adjacent lands beyond the buffer strip, unless otherwise noted. Any work done on the road allowance, with respect to excavation, disposal of materials, installation of culverts, cleaning under bridges, etc., shall be to the satisfaction of the Road Authority and the Engineer.

B.9 TRIBUTARY OUTLETS

The Contractor shall guard against damaging the outlets of tributary drains. Prior to commencement of excavation on each property the Contractor shall contact the owner and request that all known outlet pipes be marked by the owner. All outlets so marked or visible or as noted on the profile, and subsequently damaged by the Contractor's operations will be repaired by the Contractor at his cost. All outlet pipes repaired by the Contractor under direction of the Drainage Superintendent or Engineer which were not part of the Contract shall be considered an extra to the contract price.

B.10 **SEDIMENT BASINS AND TRAPS**

The Contractor shall excavate sediment basins prior to commencement of upstream work as shown on the plan and profile. The dimension of the basin will be in a parabolic shape with a depth of 450mm below the proposed ditch bottom and the basin will extend along the drain for a minimum length of 15 meters.

A sediment trap 300mm deep and 5 meters long with silt fence placed across ditch bottom on the downstream end of the trap shall be constructed prior to and maintained during construction, to prevent silt from flushing downstream. The silt fence shall be removed and disposed of after construction.

B.11 **SEEDING**

.1 **Delivery:** The materials shall be delivered to the site in the original unopened containers which shall bear the vendor's guarantee of analysis and seed will have a tag showing the year of harvest.

.2 **Hydro Seeding:** Areas specified on drawings shall be hydro seeded and mulched upon completion of construction in accordance with O.P.S.S. 572 and with the following application rates:

Primary Seed (85 kg/ha.):	50% Creeping Red Fescue 40% Perennial Ryegrass 5% White Clover
Nurse Crop	Italian (Annual) Ryegrass at 25% of Total Weight
Fertilizer (300 kg/ha.)	8-32-16
Hydraulic Mulch (2000 kg/ha.)	Type "B"
Water (52,700 litres/ha.)	

Seeding shall not be completed after September 30.

.3 **Hand Seeding:** Hand seeding shall be completed daily with the seed mixture and fertilizer and application rate shown under "Hydro Seeding" above. Placement of the seed shall be by means of an approved mechanical spreader. Seeding shall not be completed after September 30.

SECTION C - TILE DRAIN

INDEX

<u>SECTION NUMBER</u>	<u>PAGE NO.</u>
C.1 PIPE MATERIALS.....	10
C.2 TESTING.....	10
C.3 LINE.....	10
C.4 CLEARING AND GRUBBING.....	11
C.5 PROFILE.....	11
C.6 GRADE.....	11
C.7 EXCAVATION.....	11
C.8 INSTALLATION.....	12
C.9 ROAD AND LANEWAY SUB-SURFACE CROSSINGS.....	12
C.10 BACKFILLING.....	13
C.11 UNSTABLE SOIL.....	13
C.12 ROCKS.....	13
C.13 BROKEN, DAMAGED, OR EXCESS TILE.....	13
C.14 TRIBUTARY DRAINS.....	13
C.15 OUTLET PIPES.....	14
C.16 CATCHBASINS AND JUNCTION BOXES.....	14
C.17 BLIND INLETS.....	15
C.18 GRASSED WATERWAY.....	15
C.19 BACKFILLING EXISTING DITCHES.....	15
C.20 RECOMMENDED PRACTICE FOR CONSTRUCTION OF SUBSURFACE DRAINAGE SYSTEM.....	15

SECTION C

TILE DRAIN

C.1 PIPE MATERIALS

- .1 **Concrete Tile:** All tile installed under these specifications shall be sound and of first quality and shall meet all A.S.T.M. Specifications current at the time of tendering. Concrete tile shall conform to Designation C412 "Extra Quality" except that the minimum compression strengths shall be increased by 25%. Heavy Duty tile shall conform to Designation C412 "Heavy Duty Extra Quality".
- .2 **Corrugated Steel Pipe:** Unless otherwise specified, all metal pipe shall be corrugated, riveted steel pipe or helical corrugated steel pipe with a minimum wall thickness of 1.6mm (16 gauge) and shall be fully galvanized.
- .3 **Plastic Tubing:** The plans will specify the type of tubing or pipe, such as non-perforated or perforated (with or without filter material).
 - i) Corrugated Plastic Drainage Tubing shall conform to the current O.F.D.A. Standards
 - ii) Heavy Duty Corrugated Plastic Pipe shall be "Boss 1000" manufactured by the Big 'O' Drain Tile Co. Ltd. or approved equal
- .4 **Concrete Sewer Pipe:** The Designations for concrete sewer pipe shall be C14 for concrete sewer pipe 450mm (18") diameter or less; and C76 for concrete sewer pipe greater than 450mm (18") diameter. Where closed joints are specified, joints shall conform to the A.S.T.M. Specification C443.

Where concrete sewer pipe "seconds" are permitted the pipe should exhibit no damages or cracks on the barrel section and shall be capable of satisfying the crushing strength requirements for No.1, Pipe Specifications (C14 or C76). The pipe may contain cracks or chips in the bell or spigot which could be serious enough to prevent the use of rubber gaskets, but which are not so severe that the joint could not be mortared conventionally.
- .5 **Plastic Sewer Pipe:** The plans will specify the type of sewer pipe, such as non-perforated or perforated (with or without filter material). All plastic sewer pipe and fittings shall be "Boss Poly-Tite", ULTRA-RIB", "Challenger 3000" or approved equal with a minimum stiffness of 320 kpa at 5% deflection.
- .6 **Plastic Fittings:** All plastic fittings shall be "Boss 2000" or "Challenger 2000" with split coupler joints or approved equal.

C.2 TESTING

The manufacturer shall provide specimens for testing if required. The random selection and testing procedures would follow the appropriate A.S.T.M. requirements for the material being supplied. The only variation is the number of tiles tested: 200mm to 525mm dia. - 5 tile tested, 600mm to 900mm dia. - 3 tile tested. The drain will be responsible for all testing costs for successful test results. Where specimens fail to meet the minimum test requirements, the manufacturer will be responsible for the costs of the unsuccessful tests. Alternately, the Engineer may accept materials on the basis of visual inspections and the receipt in writing from the Manufacturer of the results of daily production testing carried out by the Manufacturer for the types and sizes of the material being supplied.

C.3 LINE

Prior to stringing the tile, the Contractor shall contact the Superintendent or the Engineer in order to establish the course of the drain.

Where an existing drain is to be removed and replaced in the same trench by the new drain or where the new drain is to be installed parallel to an existing drain, the Contractor shall excavate test holes to locate the existing drain (including repairing drainage tile) at intervals along the course of the drain as directed by the Engineer and/or the Superintendent. The costs for this work shall be included in the tender price.

Where an existing drain is to be removed and replaced in the same trench by the new drain, all existing tiles shall be destroyed, and all broken tile shall be disposed of offsite.

C.3 **LINE** (cont'd)

The drain shall run in as straight a line as possible throughout its length, except that at intersections of other water courses or at sharp corners, it shall run on a curve of at least a 15-meter radius. The new tile drain shall be constructed at an offset from and generally parallel with any ditch or defined watercourse in order that fresh backfill in the trench will not be eroded by the flow of surface water. The Contractor shall exercise care not to disturb any existing tile drain or drains which parallel the course of the new drain, particularly where the new and the existing tile act together to provide the necessary capacity.

C.4 **CLEARING AND GRUBBING**

Prior to commencement of drain construction, all trees, scrub, fallen timber and debris shall be cleared and grubbed from the working area. Unless otherwise specified, the minimum width to be cleared and grubbed shall be 20 meters in all hardwood areas and 30 meters in all softwood areas (willow, poplar, etc.), the width being centred on the line of the drain.

All trees or limbs 150mm (6") or larger, that it is necessary to remove, shall be considered as logs and shall be cut and trimmed, and left in the working width separate from the brush, for use or disposal by the owner. Trees or limbs less than 150mm in diameter shall be cut in lengths not greater than 5 meters and placed in separate piles with stumps spaced not less than 75 meters apart in the working width, for the use or disposal of the owner. In all cases, these piles shall be placed clear of excavated materials, and not be piled against standing trees. No windrowing will be permitted. The clearing and grubbing and construction of the drain are to be carried out in two separate operations and not simultaneously at the same location.

C.5 **PROFILE**

The profile drawing shows the depth of cuts from the ground beside the stake to the final invert of the drain in meters and decimals of a meter. These cuts are established for the convenience of the Contractor; however, benchmarks will govern the final elevation of the drain. Benchmarks have been established along the course of the drain and their locations and elevations are noted on the profile drawing.

C.6 **GRADE**

The Contractor shall provide and maintain in good working condition, an approved system of establishing a grade sight line to ensure the completed works conform to the profile drawing. In order to confirm the condition of his system and to eliminate the possibility of minor errors on the drawings, he shall ensure his grade sight line has been confirmed to be correct between a minimum of two control points (bench marks) and shall spot check the actual cuts and compare with the plan cuts prior to commencement of tile installation. He shall continue this procedure from control point to control point as construction of the drain progresses. When installing a drain towards a fixed point such as a bore pipe, the Contractor shall uncover the pipe and confirm the elevation, using the sight line, a sufficient distance away from the pipe in order to allow for any necessary minor grade adjustments to be made in order to conform to the as built elevation of the bore pipe. All tile improperly installed due to the Contractor not following these procedures shall be removed and replaced entirely at the Contractor's cost.

When following the procedures and a significant variation is found, the Contractor shall immediately cease operations and advise the Engineer.

C.7 **EXCAVATION**

- .1 **Trench:** Unless otherwise specified, all trenching shall be done with a recognized farm tiling machine approved by the Engineer or Superintendent. The machine shall shape the bottom of the trench to conform to the outside diameter of the pipe for a minimum width of one-half of the outside diameter. The minimum trench width shall be equal to the outside diameter of the tile to be installed plus 100mm (4") on each side unless otherwise approved. The maximum trench width shall be equal to the outside diameter of the tile to be installed plus 250mm (10") on each side unless otherwise approved.

C.7 **EXCAVATION** (cont'd)

- .2 **Scalping**: Where the depths of cuts in isolated areas along the course of the drain as shown on the profile exceed the capacity of the Contractor's tiling machine, he shall lower the surface grade in order that the tiling machine may trench to the correct depth. Topsoil is to be stripped over a sufficient width that no subsoil will be deposited on top of topsoil. Subsoil will then be removed to the required depth and piled separately. Upon completion of backfilling, the topsoil will then be replaced to an even depth over the disturbed area. The cost for this work shall be included in his tender price.
- .3 **Excavator**: Where the Contractor's tiling machine consistently does not have the capacity to dig to the depths required or to excavate the minimum trench width required, he shall indicate in the appropriate place provided on the tender form his proposed methods of excavation.
Where the use of an excavator is either specified on the drawings or approved as evidenced by the acceptance of his tender on which he has indicated the proposed use of a backhoe he shall conform to the following requirements:
- a) the topsoil shall be stripped and replaced in accordance with Section .2 "Scalping".
 - b) all tile shall be installed on a bed of 19mm crushed stone with a minimum depth of 150mm which has been shaped to conform to the lower segment of the tile.
 - c) the Contractor shall allow for the cost of the preceding requirements (including the supply of the crushed stone) in his lump sum tender price unless it is otherwise provided for in the contract documents.
- .4 **Backfilling Ditch**: Where the contract includes for a closed drain to replace an open drain and the ditch is to be backfilled, the Contractor shall install the tile and backfill the trench prior to backfilling the ditch unless otherwise noted. The distance the trench shall be located away from the ditch shall be as noted on the drawings, (beyond area required for stockpiling topsoil and backfilling). After tile installation is complete topsoil (if present) shall be stripped and stockpiled within the above limits prior to backfilling of ditch. Only tracked equipment shall be permitted to cross backfilled tile trench and must be at 90 degrees to line of tile.

C.8 **INSTALLATION**

The tile is to be laid with close fitting joints and in regular grade and alignment in accordance with the plan and profile drawings. The tiles are to be bevelled, if necessary, to ensure close joints (in particular around curves). Where, in heavy clay soils, the width of a joint exceeds 10mm the joint shall be wrapped with filter cloth as below. Where the width of a joint exceeds 12mm the tile shall first be removed and the joint bevelled to reduce the gap. The maximum deflection of one tile joint shall be 15 degrees. Where a drain connects to standard or ditch inlet catchbasins or junction box structures, the Contractor shall include in his tender price for the supply and installation of compacted Granular 'A' bedding under areas backfilled from the underside of the pipe to undisturbed soil. The connections will then be grouted.

Where a tile drain passes through a bore pit, the Tile Contractor shall include in his tender price for the supply and placement of compacted Granular "A" bedding from the underside of the pipe down to undisturbed soil within the limits of the bore pit.

As above and where soil conditions warrant, the Engineer may require (or as specified on the drawings) that each tile joint be wrapped with synthetic filter cloth. The width of the filter cloth shall be 300mm wide for tile sizes of 150mm to 300mm and 400mm wide for sizes of 350mm to 750mm. The filter cloth shall cover the full perimeter of the tile and overlap a minimum of 100mm or as specified on the drawings. The type of cloth shall be Mirafi 140NL for loam soils and 150N for sandy soil. Any such work not shown on the drawings shall be considered as an addition to the contract price unless specified on the drawings.

C.9 **ROAD AND LANEWAY SUB-SURFACE CROSSINGS**

All road and laneway crossings may be made with an open cut in accordance with standard detailed drawings in the specifications or on the drawings. The exact location of the crossing shall be verified and approved by the Road Authority and the Engineer and/or Superintendent.

C.10 **BACKFILLING**

As the laying of the tile progresses, blinding up to the springline including compaction by tamping (by hand) is to be made on both sides of the tile. No tile shall be backfilled until inspected by the Engineer or Drainage Superintendent unless otherwise approved by the Engineer.

The remainder of the trench shall be backfilled with special care being taken in backfilling up to a height approximately 150mm above the top of the tile to ensure that no tile breakage occurs. During the backfilling operation no equipment shall be operated in a way that would transfer loads onto the tile trench. Surplus material is to be mounded over the tile trench so that when settlement takes place the natural surface of the ground will be restored. Upon completion, a minimum cover of 600mm is required over all tile. Where stones larger than 150mm are present in the backfill material, they shall be separated from the material and disposed of by the Contractor.

Where a drain crosses a lawn area, the backfilling shall be carried out as above except that, unless otherwise specified, the backfill material shall be mechanically compacted to eliminate settlement.

C.11 **UNSTABLE SOIL**

The Contractor shall immediately contact the Engineer or Superintendent if quicksand is encountered, such that installation with a tiling machine is not possible. The Engineer shall, after consultation with the Superintendent and Contractor, determine the action necessary and a price for additions or deletions shall be agreed upon prior to further drain installation. Where directed by the Engineer, test holes are to be dug to determine the extent of the affected area. Cost of test holes shall be considered an addition to the contract price.

C.12 **ROCKS**

The Contractor shall immediately contact the Engineer or Superintendent if boulders of sufficient size and number are encountered such that the Contractor cannot continue trenching with a tiling machine. The Engineer or Superintendent may direct the Contractor to use some other method of excavating to install the drain. The basis of payment for this work shall be determined by the Engineer and Drainage Superintendent.

If only scattered large stones or boulders are removed on any project, the Contractor shall haul same to a nearby bush or fence line, or such other convenient location as approved by the Landowners(s).

C.13 **BROKEN, DAMAGED TILE OR EXCESS TILE**

The Contractor shall remove and dispose of off-site all broken (existing or new), damaged or excess tile or tiles. If the tile is supplied by the Municipality, the Contractor shall stockpile all excess tile in readily accessible locations for pickup by the Municipality upon the completion of the job.

C.14 **TRIBUTARY DRAINS**

Any tributary tile encountered in the course of the drain shall be carefully taken up by the Contractor and placed clear of the excavated earth. If the tributary tile drains encountered are clean or reasonably clean, they shall be connected into the new drain. Where existing drains are full of sediment, or contain pollutants, the decision to connect those drains to the new drain shall be left to the Engineer or Superintendent. Each tributary tile connection made by the Contractor shall be located and marked with a stake and no backfilling shall take place until the connection has been approved by the Engineer or Superintendent.

For tributary drains 150mm dia. or smaller connected to new tiles 250mm dia. or larger, and for 200mm dia. connected to 350mm dia. or larger, the Contractor shall neatly cut a hole in the middle of a tile length. The connections shall be made using a prefabricated adaptor. All other connections shall be made with prefabricated wyes or tees conforming to Boss 2000 split coupler or approved equal.

Where an open drain is being replaced by a new tile drain, existing tile outlets entering the ditch from the side opposite the new drain shall be extended to the new drain. All existing metal outlet pipes shall be carefully removed, salvaged, and left for the owner. Where the grade of the connection passes through the newly placed backfill in the ditch, the backfill material below the connection shall be thoroughly compacted and metal pipe of a size compatible with the tile outlet shall be installed so that a minimum length of 2 meters at each end is extending into undisturbed soil.

C.14 **TRIBUTARY DRAINS** (cont'd)

Where locations of tiles are shown on the drawings the Contractor shall include in his tender price, all costs for connecting those tiles to the new drain regardless of length.

Where tiles not shown on the drawings are encountered in the course of the drain, and are to be connected to the new drain, the Contractor shall be paid for each connection at the rate outlined in the Form of Tender and Agreement.

C.15 **OUTLET PIPES**

Corrugated steel pipe shall be used to protect the tile at its outlet. It shall have a hinged metal grate with a maximum spacing between bars of 40mm. The corrugated steel pipe shall be bevelled at the end to generally conform to the slope of the ditch bank and shall be of sufficient size that the tile can be inserted into it to provide a solid connection. The connection will then be grouted immediately.

The installation of the outlet pipe and the required rip-rap protection shall conform to the standard detailed drawing as noted on the drawing.

C.16 **CATCHBASINS AND JUNCTION BOXES**

- .1 **Catchbasins**: Unless otherwise noted or approved, catchbasins shall be in accordance with O.P.S.D. 705.010, 705.030. All catchbasins shall include two - 150mm riser sections for future adjustments. All ditch inlet catchbasins shall include one 150mm riser section for future adjustments. The catchbasin top shall be a "Bird Cage" type substantial steel grate, removable for cleaning and shall be inset into a recess provided around the top of the structure. The grate shall be fastened to the catchbasin with bolts into the concrete. Spacing of bars on grates for use on 600mmx600mm structures shall be 65mm centre to centre. Spacing of bars on grates for use on structures larger than 600mmx600mm shall be 90mm with a steel angle frame.

The exact location and elevation of catchbasins shall be approved by the Road Authority or the Engineer/Superintendent. Catchbasins offset from the drain shall have "Boss 2000" 200mm diameter leads or approved equal unless otherwise noted and the leads shall have a minimum of 600mm of cover. The leads shall be securely grouted at the structures and the drain.

- .2 **Junction Boxes**: Junction boxes shall be the precast type unless otherwise approved. Dimensions for precast junction boxes shall conform to those for catchbasins. The inside dimensions of the box shall be a minimum of 100mm larger than the outside diameter of the largest pipe being connected. The minimum cover over the junction box shall be 600mm. Benching to spring line shall be supplied with all junction boxes.
- .3 **Connections**: Catchbasins and junction boxes shall not be ordered until elevations of existing pipes being connected have been verified in the field as indicated on the drawings. All connections shall be securely grouted at both the inside and outside walls of the structure.
- .4 **Installation**: Where the native material is clay, all catchbasins shall be backfilled with an approved granular material placed and compacted to a minimum width of 300mm on all sides with the following exception. Where the native material is sandy or granular in nature it may be used as backfill. Filter cloth shall be placed between the riser sections of all catchbasins.

Where the Contractor has over excavated or where ground conditions warrant, the structure shall be installed on a compacted granular base.

The Contractor shall include in his tender price for the construction of a berm behind all ditch inlet structures. The berm shall be constructed of compacted clay keyed 300mm into undisturbed soil. Topsoil shall be distributed to a 65mm thickness and seeded unless otherwise specified. The Contractor shall also include for regrading, shaping and seeding of road ditches for a maximum of 15 meters each way from all catchbasins.

C.17 **BLIND INLETS**

Where specified, blind inlets shall be installed along the course of the drain in accordance with details on the drawings.

C.18 **GRASSED WATERWAY**

Topsoil to be stripped from construction area and stockpiled prior to construction of waterway. Waterway to be graded into a parabolic shape to the width shown on the drawings. Topsoil to be relevelled over the waterway and other areas disturbed by construction.

Waterway to be prepared for seeding by harrowing and then seeded by drilling followed by rolling. Seeding rate to be 85 Kg/Ha with the following mixture:

- 30% Canon Canada Bluegrass
- 25% Koket Chewings Fescue
- 30% Rebel Tall Fescue
- 15% Diplomat Perennial Rye
- Plus #125 Birdsfoot Trefoil (25% of Total Weight)

C.19 **BACKFILLING EXISTING DITCHES**

The Contractor shall backfill the ditch sufficiently for traversing by farm machinery. If sufficient material is not available from the old spoil banks to fill in the existing ditch, the topsoil shall be stripped and the subsoil shall be bulldozed into the ditch and the topsoil shall then be spread over the backfilled ditch unless otherwise specified on the contract drawings. The Contractor shall ensure sufficient compaction of the backfill and if required, repair excess settlement up to the end of the warranty period. The final grade of the backfilled ditch shall provide an outlet for surface water.

C.20 **RECOMMENDED PRACTICE FOR CONSTRUCTION OF SUBSURFACE DRAINAGE SYSTEM**

Drainage guide for Ontario, Ministry of Agriculture, Food and Rural Affairs Publication Number 29 and its amendments, dealing with the construction of Subsurface Drainage systems, shall be the guide to all methods and materials to be used in the construction of tile drains except where superseded by other specifications of this contract.

The requirements of licensing of operators, etc. which apply to the installation of closed drains under the Tile Drainage Act shall also be applicable to this contract in full unless approval otherwise is given in advance by the Engineer.

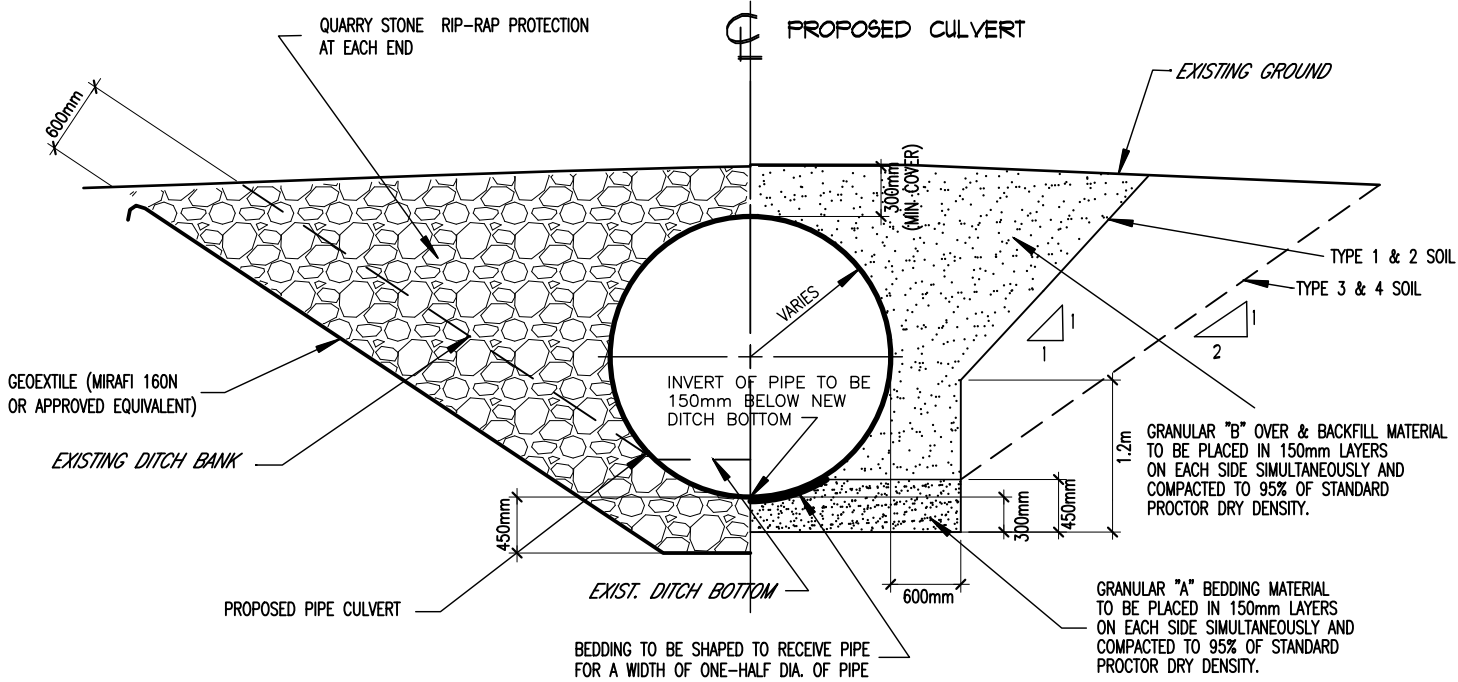

HALF ELEVATION

HALF SECTION

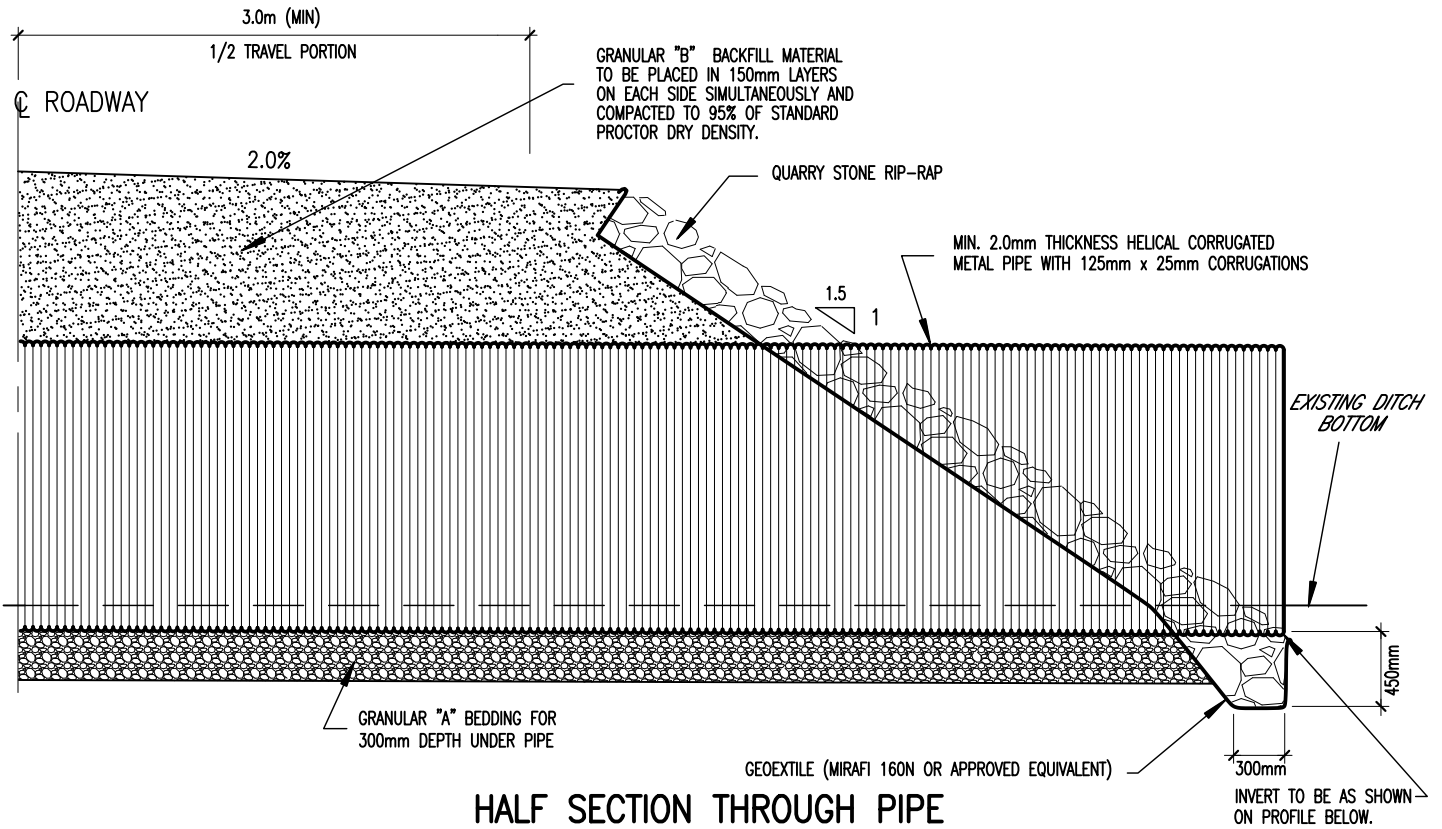

NOTES

- 1) WHERE THE CULVERT IS TO BE INSTALLED IN POOR SOIL CONDITIONS, THE BEDDING MATERIAL SHALL BE 19mm CRUSHED STONE COMPLETELY WRAPPED IN GEOTEXTILE SUCH AS MIRAFI 160N OR APPROVED EQUIVALENT.

TYPICAL FARM CULVERT INSTALLATION DETAIL		
Scale: N.T.S.	Approved by:	Date: January 1983
Drawn by: jk	M.P.D.	Revised: November 2000
ELEVATION & SECTION		STANDARD DETAILED DRAWING
 SPRIET ASSOCIATES LONDON LIMITED CONSULTING ENGINEERS ARCHITECTS		No. 01

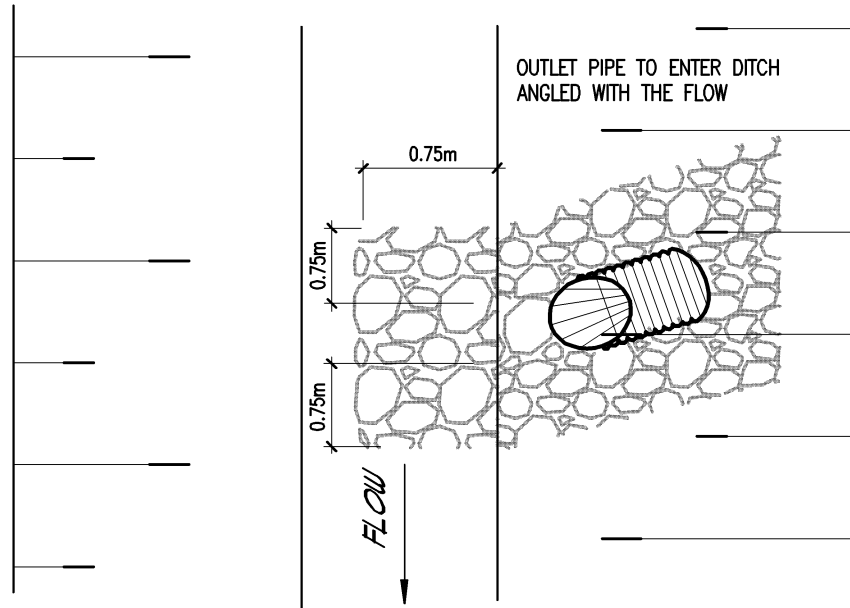

PLAN

NOTES

1. WHERE THE DISTURBED AREA EXCEEDS THE MIN. WIDTHS, RIP-RAP TO EXTEND TO A MIN. OF 600mm BEYOND THE DISTURBED AREA

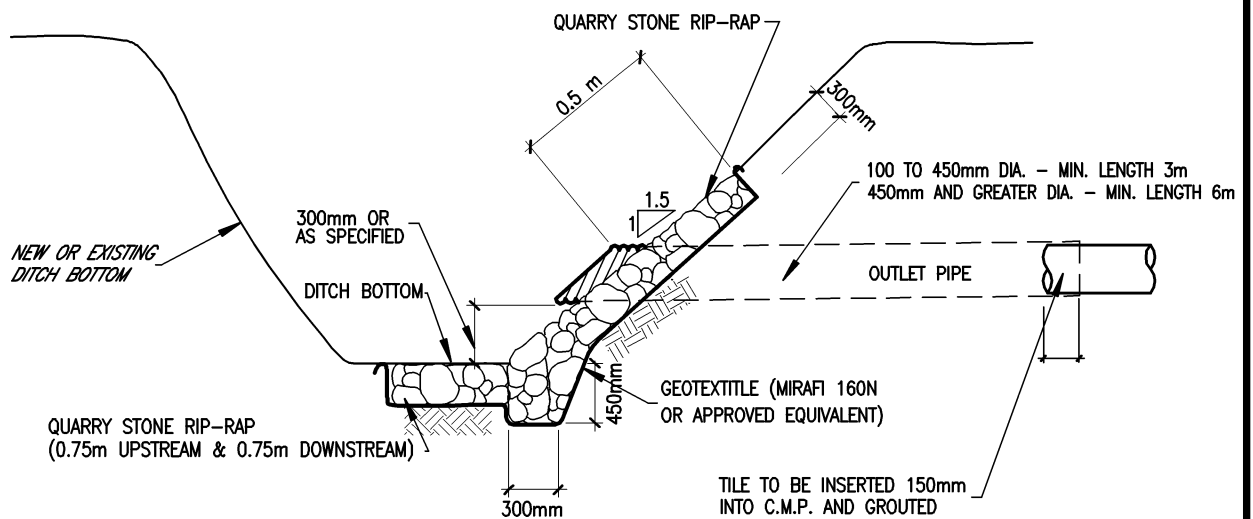

TYPICAL OUTLET RIP-RAP

NOTES

1. RIP-RAP TO EXTEND UP THE SLOPE 0.5 METER ABOVE TOP OF OUTLET
2. WHERE SURFACE RUN ENTERS DITCH AT OUTLET PIPE, A ROCK CHUTE SHALL BE INSTALLED (SEE S.D.D. No. 05) AND PIPE SHALL BE INSTALLED ADJACENT TO ROCK CHUTE.
3. HINGED RODENT GATE TO BE AFFIXED TO END OF OUTLET PIPE.

TYPICAL OUTLET RIP-RAP THROUGH SIDE SLOPE OF DITCH

Scale: N.T.S.

Approved by:

Date: November 2000

Drawn by: jk

M.P.D.

Revised: January 2009

PLAN & SECTION



SPRIET ASSOCIATES LONDON LIMITED
CONSULTING ENGINEERS ARCHITECTS

STANDARD
DETAILED
DRAWING
No. 03

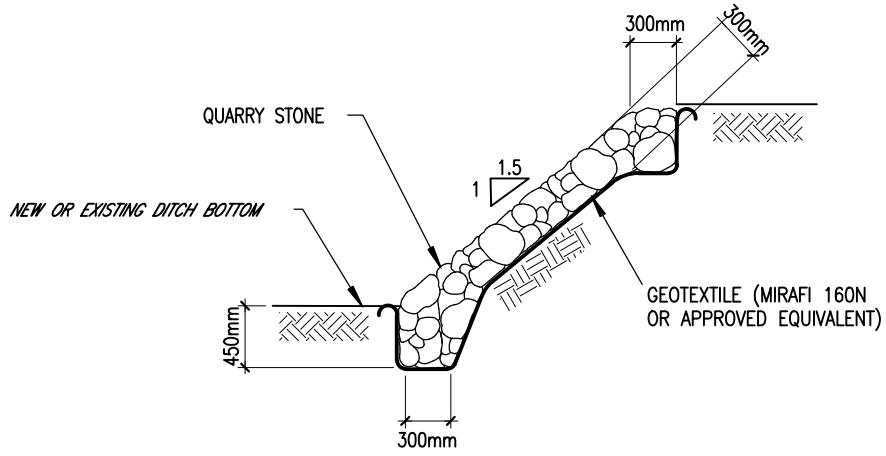

TYPICAL DITCH BANK RIP-RAP

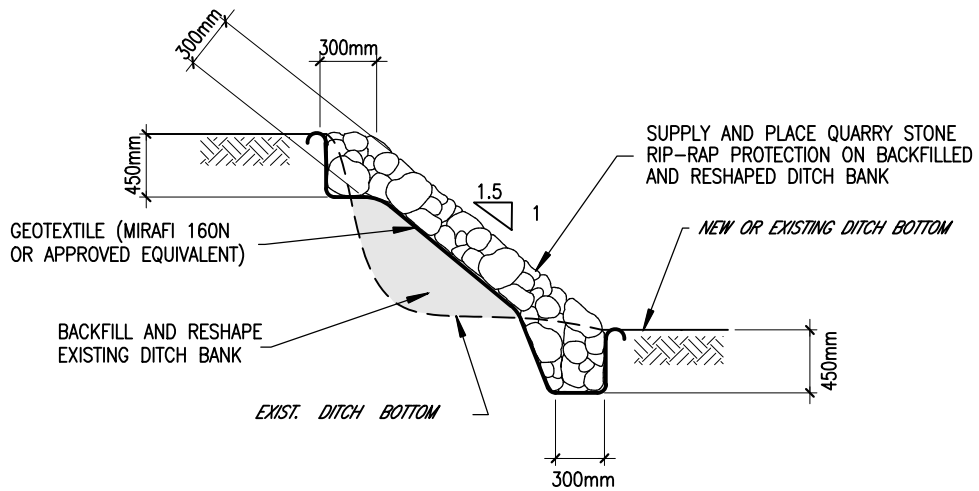

TYPICAL DITCH BANK RIP-RAP WITH BACKFILLING OF WASHOUT

TYPICAL DITCH BANK RIP-RAP DETAILS

Scale: N.T.S.	Approved by:	Date: July 2000
Drawn by: jk	M.P.D.	Revised: November 2000

SECTIONS		STANDARD DETAILED DRAWING No. 04
 SPRIET ASSOCIATES LONDON LIMITED CONSULTING ENGINEERS ARCHITECTS		

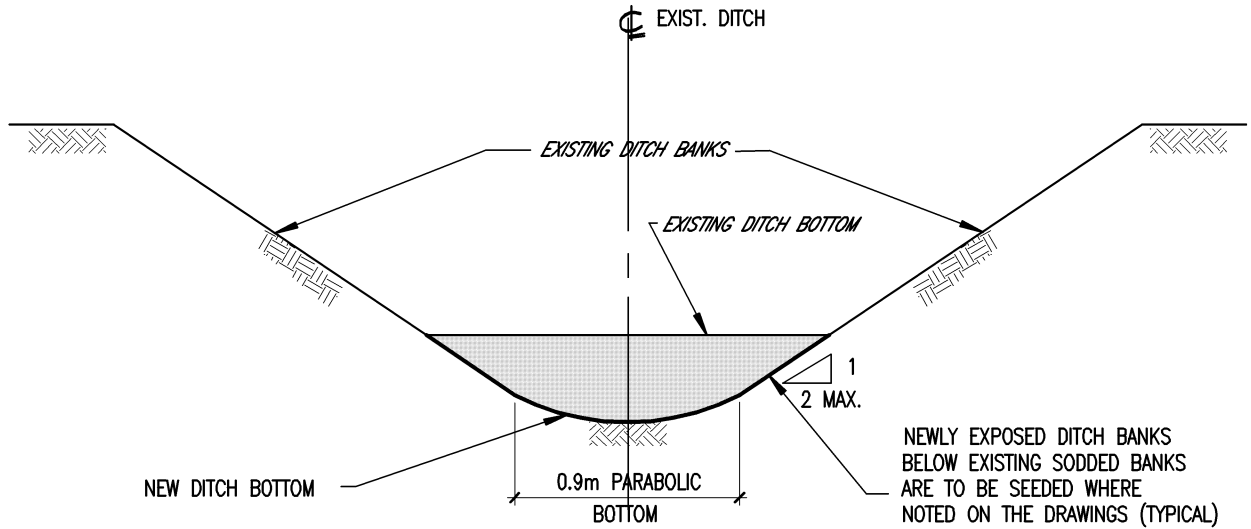

TYPICAL DITCH BOTTOM CLEANOUT

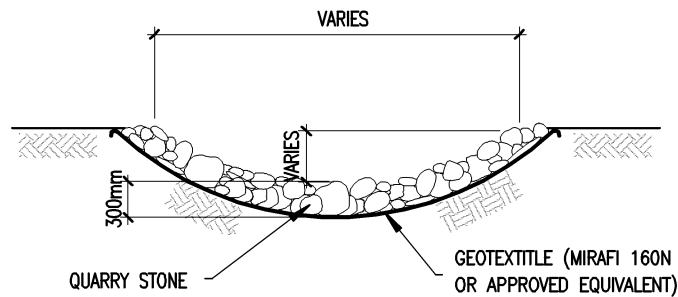
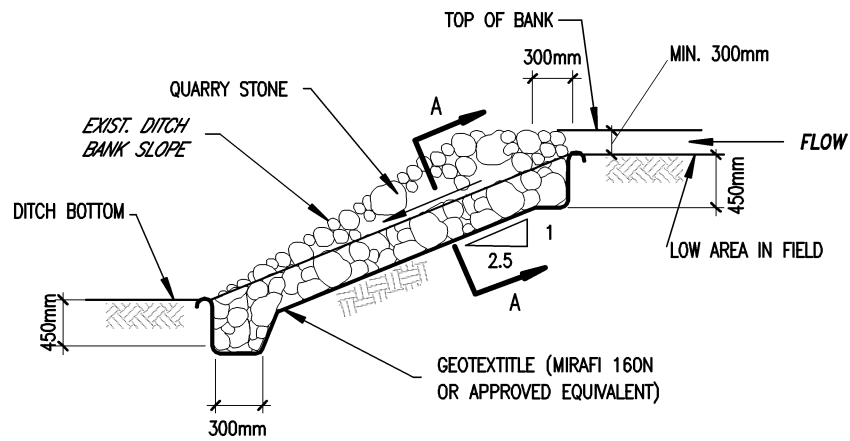

SECTION A-A

TYPICAL ROCK CHUTE

TYPICAL DITCH BOTTOM CLEANOUT TYPICAL ROCK CHUTE CONSTRUCTION		
Scale: N.T.S.	Approved by:	Date: November 2000
Drawn by: jk	M.P.D.	Revised:
SECTIONS		STANDARD DETAILED DRAWING No. 05
 SPRIET ASSOCIATES LONDON LIMITED CONSULTING ENGINEERS ARCHITECTS		

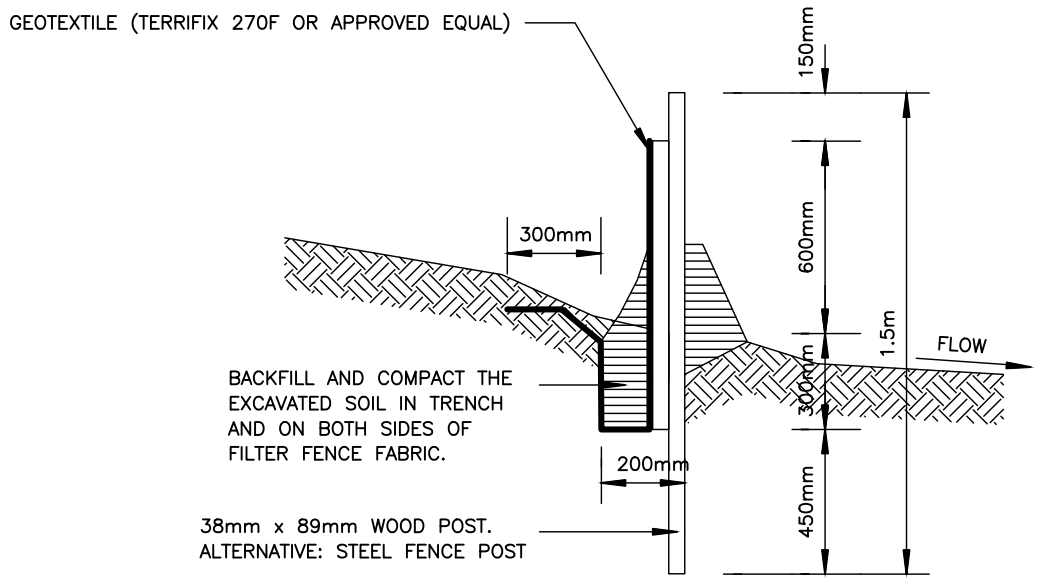
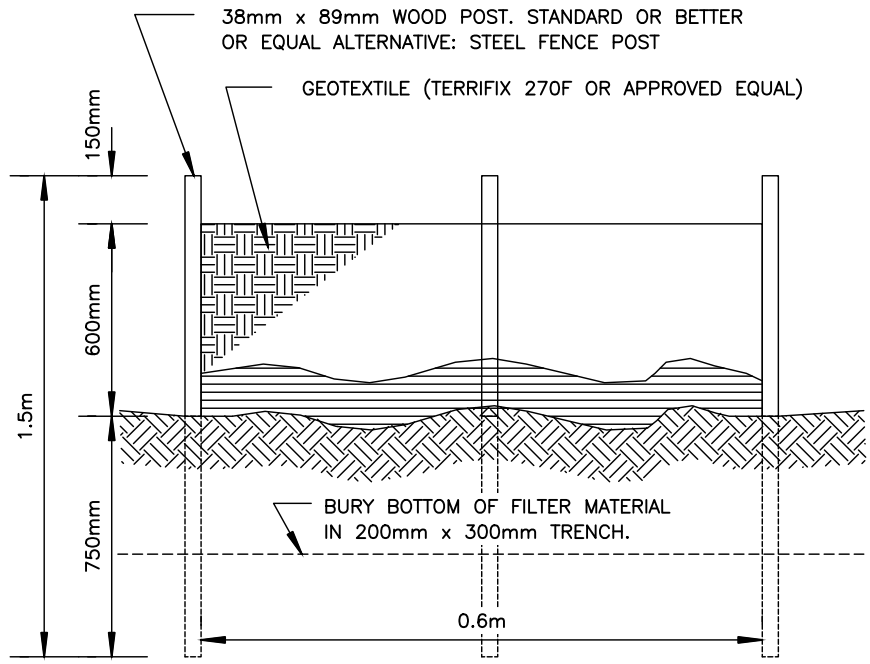

SILT FENCE DETAIL

Scale: N.T.S.	Approved by:	Date: February 2025
Drawn by: TF	M.P.D.	Revised:

SECTION

 **SPRIET ASSOCIATES LONDON LIMITED**
CONSULTING ENGINEERS ARCHITECTS

STANDARD
DETAILED
DRAWING
No. 08